

SPYDER[®]

PRO POWERED TOOLS



2023

MERCHANDISING CATALOG

PROFESSIONAL TOOLS, WORLD-CLASS INNOVATION

Cutting, drilling, scraping and sawing are hard work, but they don't have to be. There's a smarter way to tackle these time-consuming, labor-intensive, sweat-inducing jobs. **Spyder's innovative power tool attachments are engineered to work harder, complete the job faster and last longer – up to 40x faster and 100x longer tool life!** Using quality materials and innovative designs, our power tool accessories stand up to the punishment that is dished out every day – working as long and hard as the pros who depend on them.

Since our inception in 2008, when the Spyder Scraper® won **New Product of the Year at the National Hardware Show**, we continue to win awards for our innovation and quality. From the versatility of a 3-way cut reciprocating saw blade to effortless hole boring to the ingenious design of an arbor system that removes hole saw cores with a push of a button, every tool is meticulously engineered and constructed to provide significant advantages over the standard way of doing things. **The result is an entire line of high-quality, high-performance tools that save time, effort and money.**

We make the tools that professionals use to power through the toughest jobs without the downtime and frustration of conventional tools. **Spyder is the go-to source when looking for quality, ease of use, leading-edge performance and value.**

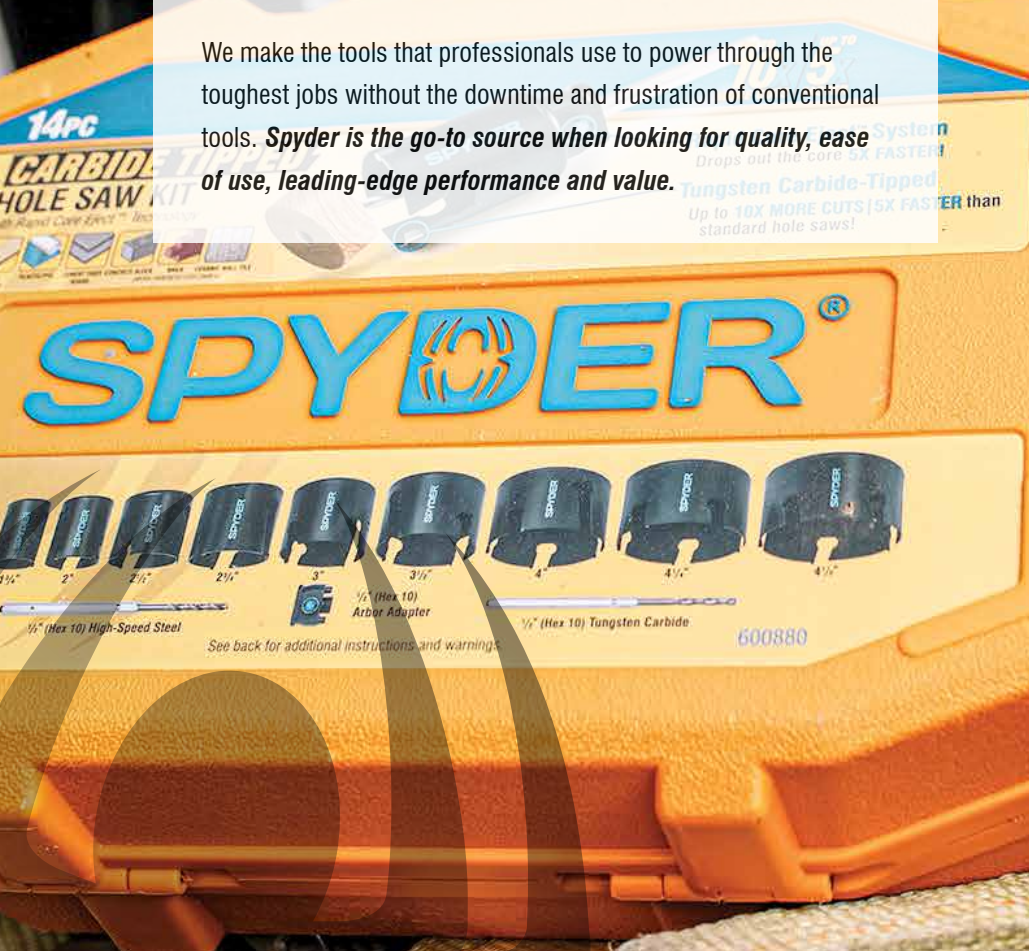

PRO POWERED TOOLS

SPYDER® FULL 24FT PRODUCT LINE- 900836	2
SPYDER® WOOD BORING	4
Stinger™ Spade Bits- 11037	
6-1/2-in Stinger™ Auger Bits- 12034	
18-in Stinger™ Auger Bits- 12035	
Stinger™ Auger Bit Complete Assortment- 12033	
Stinger™ Power Bit Complete Assortment- 900833	
Wood Boring Bits- 900832	
32-in Wood-Metal Drilling Rolling Floorstand Display- 900690	
SPYDER® LINEAR EDGE	15
3X3™ Double-Sided Reciprocating Saw Blades- 200326	
3X3™ Double-Sided Reciprocating Saw Blade Counter Display- 200329	
Mach-Blue™ Reciprocating Saw Blades- 200328	
Black Series™ Bi-Metal Reciprocating Saw Blades- 200327	
TCT Reciprocating Saw Blades- 200325	
Everyday Jig Saw Blades- 300103	
Reciprocating Accessories Packaged- 900843	
Small Reciprocating Accessories Wire Rack- 900828	
Large Reciprocating Accessories Wire Rack- 900829	
Oscillating Tool Blades- 70100	
32-in Linear Edge Rolling Floorstand Display- 900837	
Complete Linear Edge Assortment- 900842	
SPYDER® HOLE SAWS	28
Electrical Tungsten Carbide Tipped (TCT) Hole Saws- 600984	
Plumbing Tungsten Carbide Tipped (TCT) Hole Saws- 600985	
Complete Assortment Tungsten Carbide Tipped (TCT) Hole Saws- 600983	
Electrical Tarantula™ Hole Saws- 600987	
Plumbing Tarantula™ Hole Saws- 600988	
Complete Assortment Tarantula™ Hole Saws- 600986	
Electrical Bi-Metal Hole Saws- 600981	
Plumbing Bi-Metal Hole Saws- 600982	
Complete Assortment Bi-Metal Hole Saws- 600980	
Hole Saw Kits- 600976	
TCT Deep Cut Hole Saws- 600989	
Rapid Core Eject™ Arbor System- 600978	
Hole Saw Bit Extensions- 600975	
Complete Assortment Hole Saws- 600990	
SPYDER® DIAMOND	44
Diamond Bite™ Cut-Off Wheel- 14138	
Diamond Bite™ Masonry Blades- 14137	
Diamond Bite™ Complete Assortment- 14136	
32-in Diamond Bite™ Rolling Floorstand Display- 14139	
Diamond Edge Hole Saws- 600979	
SPYDER® CIRCULAR SAW BLADES	49
Small Diameter Circular Saw Blades- 13085	
Large Diameter Circular Saw Blades- 13084	
DADO Circular Saw Blades- 13082	
Circular Saw Blades Complete Assortment- 13083	
32-in Circular Saw Blade Rolling Floorstand Display- 900689	
Steel Cutting Circular Saw Blades- 13511	
SPYDER® MACH-BLUE™	57
Mach-Blue™ Drill Bits- 19320	
Mach-Blue™ Step Drill Bits- 19325	
Mach-Blue™ Driver Bits- 19323	
Impact Extensions & Bit Holders- 19324	
Mach-Blue™ Drill & Driver Bits- 19321	
32-in Mach-Blue™ Driver Bit Rolling Floorstand Display- 19326	
SPYDER® MERCHANDISING	65

SPYDER FULL PRODUCT LINE 24FT

900836

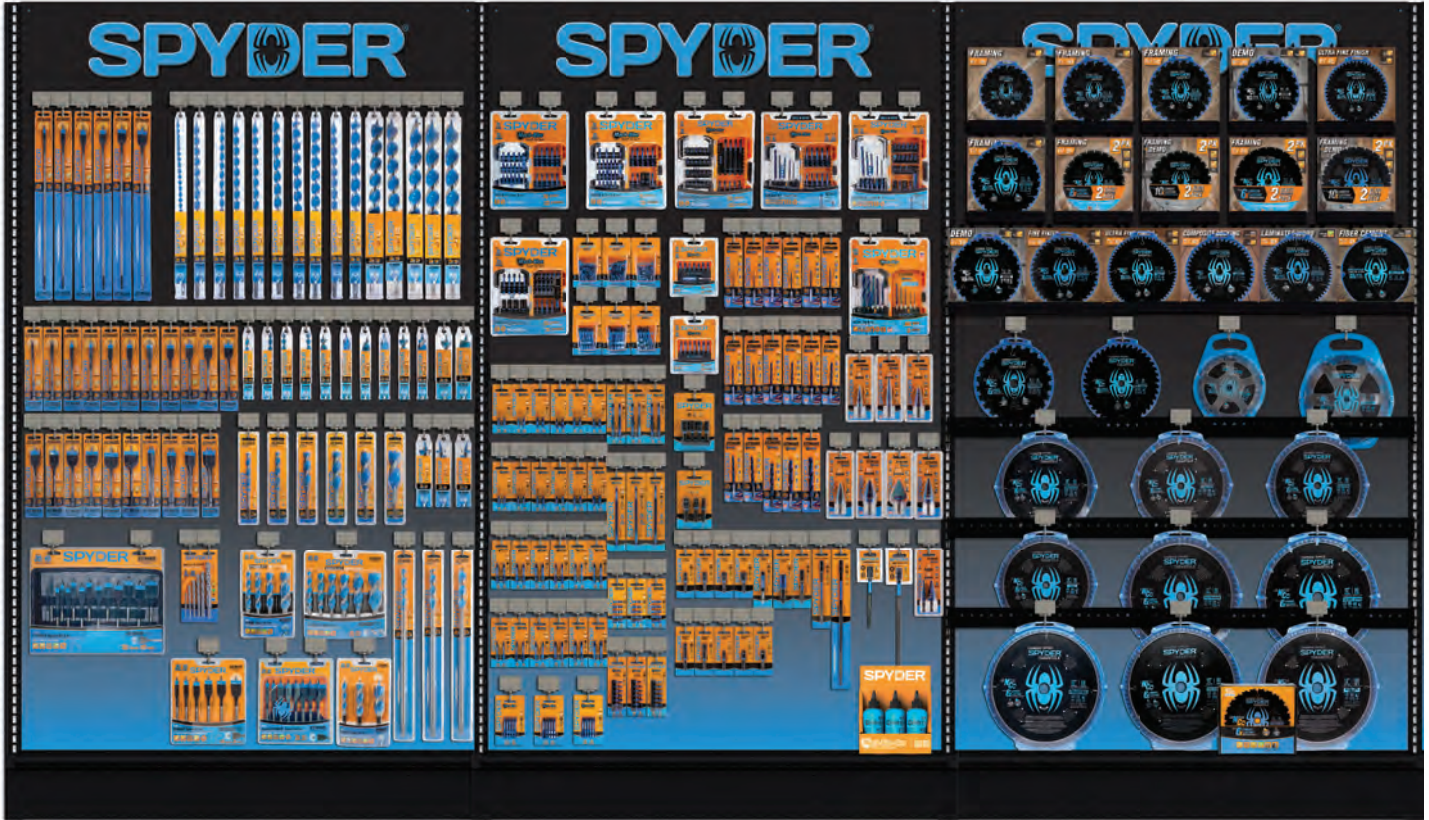

Item#	Description	QTY
900760	4ft Spyder Gondola Graphic Backpanel	1
900712	4in Metal Wire Scan Hooks .225IN DIA	40
13083	Circular Saw Blades	1
14136	Diamond Bite Blades	1
19321	Mach-Blue Drill & Driver Bits	1
900842	Linear Edge	1
600990	Hole Saw	1
600979	Diamond Hole Saw	1
900832	Wood Boring Bits	1

	Optional	QTY
	Special Order 48" x 84" Spyder Wall Gondola	6



PRO POWERED TOOLS

SPYDER FULL PRODUCT LINE 24FT

900836

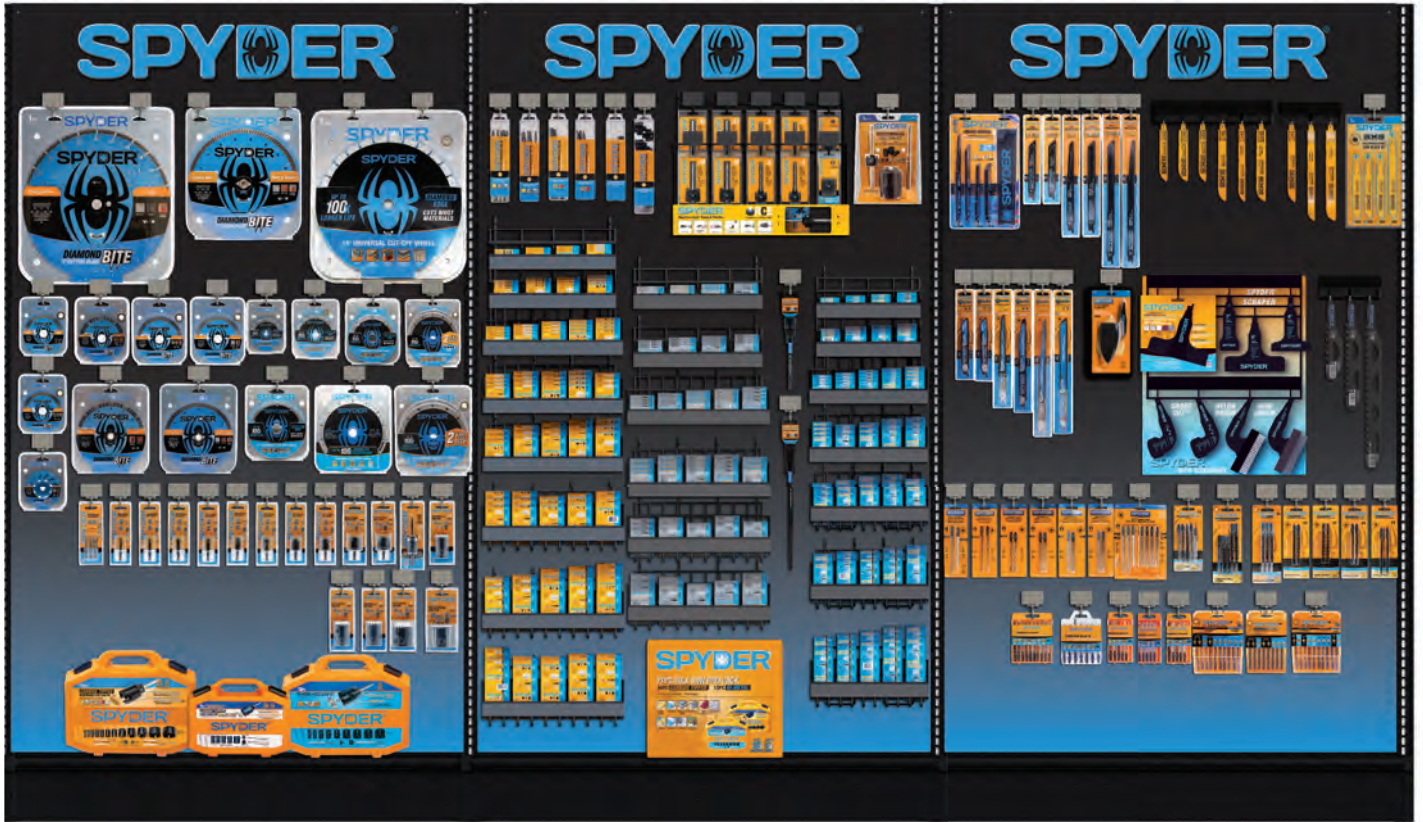

WOOD BORING

LINEAR EDGE

HOLE SAWS

DIAMOND

CIRCULAR SAWS

MACH-BLUE™

MERCHANDISING

STINGER™ SPADE BITS

Won't Clog, Won't Wander and Drills Faster than the competition

- Up to **20x faster** than conventional spade bits.
- Up to **10x more** holes than conventional spade bits,
- Automatically engages the work surface for no-thrust drilling.
- Features innovative non-clogging, automatic-feeding precision tip for optimal speed and accuracy.
- Unlike other spade bits with a self-feeding thread point, this patent pending tip won't clog, won't wander, and drills faster than the competition.
- Impact rated for use in battery-powered impacting tools.
- 1/4" speed hex won't slip in the chuck and fits quick-change impact drivers.



Patent Pending
Tip Won't Clog,
Won't Wander.

1/4" Speed Hex
Won't Slip in the
Chuck, Fits
Quick-Change
Impact Drivers.

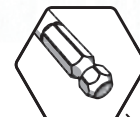

SPEED HEX



Available in 6" & 16" lengths

UP TO
20x
FASTER

UP TO
10x
MORE



WOOD

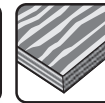

PLYWOOD

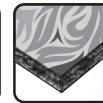

LAMINATE/
MELAMINE

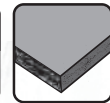

MDF



STINGER™ SPADE BITS

11037

Item#	Description	QTY
900520	REORDER BACKCARDS	32
11001	SPY 14-PC SPADE BIT SET W/POUCH	2
11002	SPY 6-PC SPADE BIT SET	2
11026	SPY 8-PC SPADE BIT SET WITH HARD CASE	2
11003	SPY Stinger Spade Bit 1/4" X 6"	2
11004	SPY Stinger Spade Bit 5/16" X 6"	2
11005	SPY Stinger Spade Bit 3/8" X 6"	2
11006	SPY Stinger Spade Bit 7/16" X 6"	2
11007	SPY Stinger Spade Bit 1/2" X 6"	2
11008	SPY Stinger Spade Bit 9/16" X 6"	2
11009	SPY Stinger Spade Bit 5/8" X 6"	2
11010	SPY Stinger Spade Bit 11/16" X 6"	2
11011	SPY Stinger Spade Bit 3/4" X 6"	2
11012	SPY Stinger Spade Bit 13/16" X 6"	2
11013	SPY Stinger Spade Bit 7/8" X 6"	2
11014	SPY Stinger Spade Bit 15/16" X 6"	2
11015	SPY Stinger Spade Bit 1" X 6"	2
11016	SPY Stinger Spade Bit 1-1/8" X 6"	2
11017	SPY Stinger Spade Bit 1-1/4" X 6"	2
11018	SPY Stinger Spade Bit 1-3/8" X 6"	2
11019	SPY Stinger Spade Bit 1-1/2" X 6"	2
11029	SPY Stinger Spade Bit 1/2" X 6" - 2PK	2
11030	SPY Stinger Spade Bit 5/8" X 6" - 2PK	2
11031	SPY Stinger Spade Bit 3/4" X 6" - 2PK	2
11033	SPY Stinger Spade Bit 1" X 6" - 2PK	2
11020	SPY Stinger Spade Bit 3/8" X 16"	2
11021	SPY Stinger Spade Bit 1/2" X 16"	2
11022	SPY Stinger Spade Bit 5/8" X 16"	2
11023	SPY Stinger Spade Bit 3/4" X 16"	2
11024	SPY Stinger Spade Bit 7/8" X 16"	2
11025	SPY Stinger Spade Bit 1" X 16"	2



STINGER™ AUGER BITS

Vibrates less, making it easier to control - even in nail-embedded wood

- Up to **20x faster** than conventional auger bits.
- Up to **10x more** holes than conventional auger bits,
- Automatically engages the work surface for no-thrust drilling.
- Features innovative non-clogging, automatic-feeding precision tip for optimal speed and accuracy.
- Hardened cutting edges power through nail-embedded wood.
- Impact rated for use in battery-powered impacting tools.
- Two flute design provides optimal chip flow and reduced cutting friction.
- 7/16" speed hex won't slip in the chuck and fits quick change tools.
- Black oxide finish provides increased durability and lubricity.

UP TO **20x** FASTER
UP TO **10x** MORE

7/16" Speed Hex Won't Slip in the chuck, Fits Quick Change Tools.



SPEED HEX

Two Flute Design Provides Optimal Chip Flow and Reduced Friction.



Available in 6-1/2" & 18" lengths



Self Feeding Thread Point Won't Clog, Won't Wander, and Drills Faster.



WOOD/NAILS

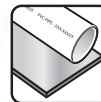

PLASTIC/PVC

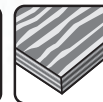

PLYWOOD

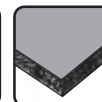

MDF



LAMINATED WOOD

STINGER™ 6-1/2-IN AUGER BITS

12034

Item#	Description	QTY
900520	REORDER BACKCARDS	18
12001	SPY 3-PC 6-IN AUGER BIT SET	2
12002	SPY 3/8-in X 6-1/2-IN AUGER BIT	2
12031	SPY 7/16-in X 6-1/2-IN AUGER BIT	2
12003	SPY 1/2-in X 6-1/2-IN AUGER BIT	2
12004	SPY 5/8-in X 6-1/2-IN AUGER BIT	2
12005	SPY 11/16-in X 6-1/2-IN AUGER BIT	2
12006	SPY 3/4-in X 6-1/2-IN AUGER BIT	2
12007	SPY 13/16-in X 6-1/2-IN AUGER BIT	2
12008	SPY 7/8-in X 6-1/2-IN AUGER BIT	2
12009	SPY 15/16-in X 6-1/2-IN AUGER BIT	2
12010	SPY 1-in X 6-1/2-IN AUGER BIT	2
12011	SPY 1-1/16-in X 6-1/2-IN AUGER BIT	2
12012	SPY 1-1/8-in X 6-1/2-IN AUGER BIT	2
12013	SPY 1-1/4-in X 6-1/2-IN AUGER BIT	2
12014	SPY 1-3/8-in X 6-1/2-IN AUGER BIT	2
12015	SPY 1-1/2-in X 6-1/2-IN AUGER BIT	2



STINGER™ 18-IN AUGER BITS

12035

Item#	Description	QTY
900520	REORDER BACKCARDS	18
12016	SPY 3/8-in X 18-IN AUGER BIT	2
12024	SPY 7/16-in X 18-IN AUGER BIT	2
12017	SPY 1/2-in X 18-IN AUGER BIT	2
12018	SPY 5/8-in X 18-IN AUGER BIT	2
12025	SPY 11/16-in X 18-IN AUGER BIT	2
12019	SPY 3/4-in X 18-IN AUGER BIT	2
12026	SPY 13/16-in X 18-IN AUGER BIT	2
12020	SPY 7/8-in X 18-IN AUGER BIT	2
12027	SPY 15/16-in X 18-IN AUGER BIT	2
12021	SPY 1-in X 18-IN AUGER BIT	2
12028	SPY 1-1/16-in X 18-IN AUGER BIT	2
12029	SPY 1-1/8-in X 18-IN AUGER BIT	2
12022	SPY 1-1/4-in X 18-IN AUGER BIT	2
12030	SPY 1-3/8-in X 18-IN AUGER BIT	2
12023	SPY 1-1/2-in X 18-IN AUGER BIT	2



STINGER™ AUGER BITS

12033

Item#	Description	QTY
900520	REORDER BACKCARDS	35
12001	SPY 3-PC 6-IN AUGER BIT SET	2
12002	SPY 3/8-in X 6-1/2-IN AUGER BIT	2
12031	SPY 7/16-in X 6-1/2-IN AUGER BIT	2
12003	SPY 1/2-in X 6-1/2-IN AUGER BIT	2
12004	SPY 5/8-in X 6-1/2-IN AUGER BIT	2
12005	SPY 11/16-in X 6-1/2-IN AUGER BIT	2
12006	SPY 3/4-in X 6-1/2-IN AUGER BIT	2
12007	SPY 13/16-in X 6-1/2-IN AUGER BIT	2
12008	SPY 7/8-in X 6-1/2-IN AUGER BIT	2
12009	SPY 15/16-in X 6-1/2-IN AUGER BIT	2
12010	SPY 1-in X 6-1/2-IN AUGER BIT	2
12011	SPY 1-1/16-in X 6-1/2-IN AUGER BIT	2
12012	SPY 1-1/8-in X 6-1/2-IN AUGER BIT	2
12013	SPY 1-1/4-in X 6-1/2-IN AUGER BIT	2
12014	SPY 1-3/8-in X 6-1/2-IN AUGER BIT	2
12015	SPY 1-1/2-in X 6-1/2-IN AUGER BIT	2
12016	SPY 3/8-in X 18-IN AUGER BIT	2
12024	SPY 7/16-in X 18-IN AUGER BIT	2
12017	SPY 1/2-in X 18-IN AUGER BIT	2
12018	SPY 5/8-in X 18-IN AUGER BIT	2
12025	SPY 11/16-in X 18-IN AUGER BIT	2
12019	SPY 3/4-in X 18-IN AUGER BIT	2
12026	SPY 13/16-in X 18-IN AUGER BIT	2
12020	SPY 7/8-in X 18-IN AUGER BIT	2
12027	SPY 15/16-in X 18-IN AUGER BIT	2
12021	SPY 1-in X 18-IN AUGER BIT	2
12028	SPY 1-1/16-in X 18-IN AUGER BIT	2
12029	SPY 1-1/8-in X 18-IN AUGER BIT	2
12022	SPY 1-1/4-in X 18-IN AUGER BIT	2
12030	SPY 1-3/8-in X 18-IN AUGER BIT	2
12023	SPY 1-1/2-in X 18-IN AUGER BIT	2

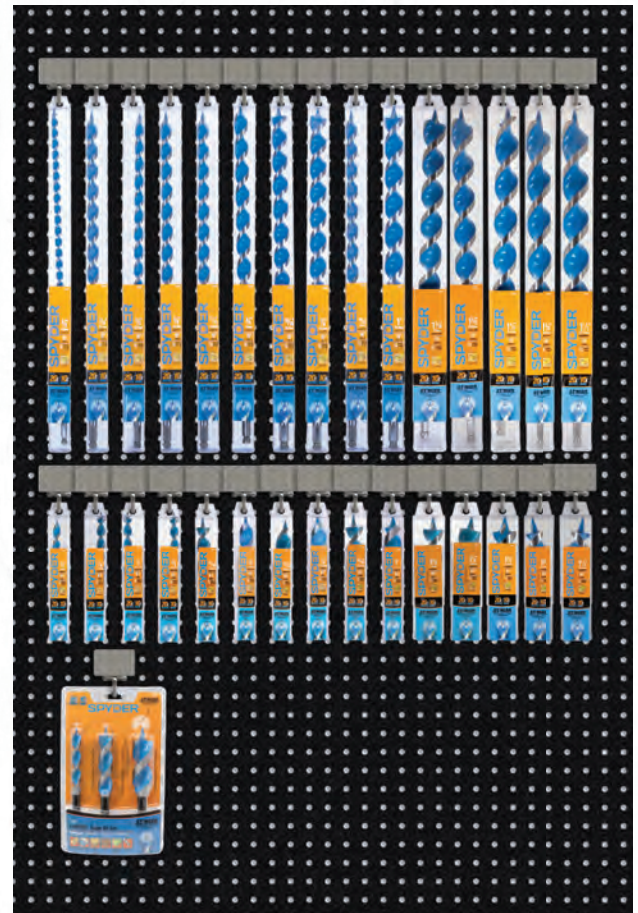

STINGER™ POWER BITS™

Bores Faster with Less Torque; Excellent for Fast, Clean, Precise Applications

- Up to **40x faster** than conventional spade bits.
- Up to **25x more** holes per charge than conventional spade bits.
- Up to **50% less** drilling torque than other threaded wood boring bits.
- Create extremely clean entry and exit holes.
- Use on high or low torque drills - drill more holes, save battery power.
- Impact ready with 1/4" speed hex.
- Ideal for use on soft and hard woods, laminated wood and particle boards.

POWER BIT FAST CLEAN™

UP TO
40x
FASTER

UP TO
25x
MORE

UP TO
50%
LESS TORQUE

Impact Ready
1/4" Speed Hex.



IMPACT HEX



Available in 6-1/2" & 16" lengths



Extremely Clean
Entry & Exit Holes.



STINGER™ POWER BITS™

900833

Item#	Description	QTY
900520	REORDER BACKCARDS	14
15001	SPY Stinger™ Power Bit™ 4pc Set	2
15003	SPY Stinger™ Power Bit™ 6pc Set	2
15004	SPY 1/2-in X 6-1/2-in Power Bit	2
15005	SPY 5/8-in X 6-1/2-in Power Bit	2
15006	SPY 3/4-in X 6-1/2-in Power Bit	2
15007	SPY 7/8-in X 6-1/2-in Power Bit	2
15008	SPY 1-in X 6-1/2-in Power Bit	2
15012	SPY 1-1/4-in X 6-1/2-in Power Bit	2
15009	SPY 1/2-in X 16-in Power Bit	2
15010	SPY 5/8-in X 16-in Power Bit	2
15011	SPY 3/4-in X 16-in Power Bit	2
11035	SPY STINGER 6PC BRAD POINT SET	2

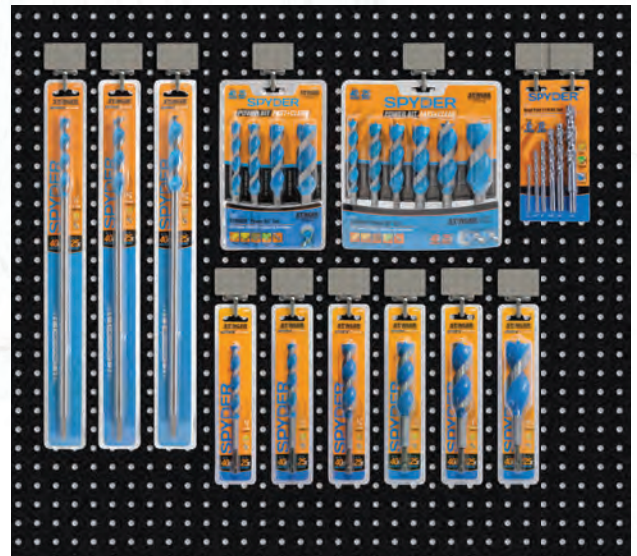

COMPLETE WOOD BORING BIT ASSORTMENT

900832

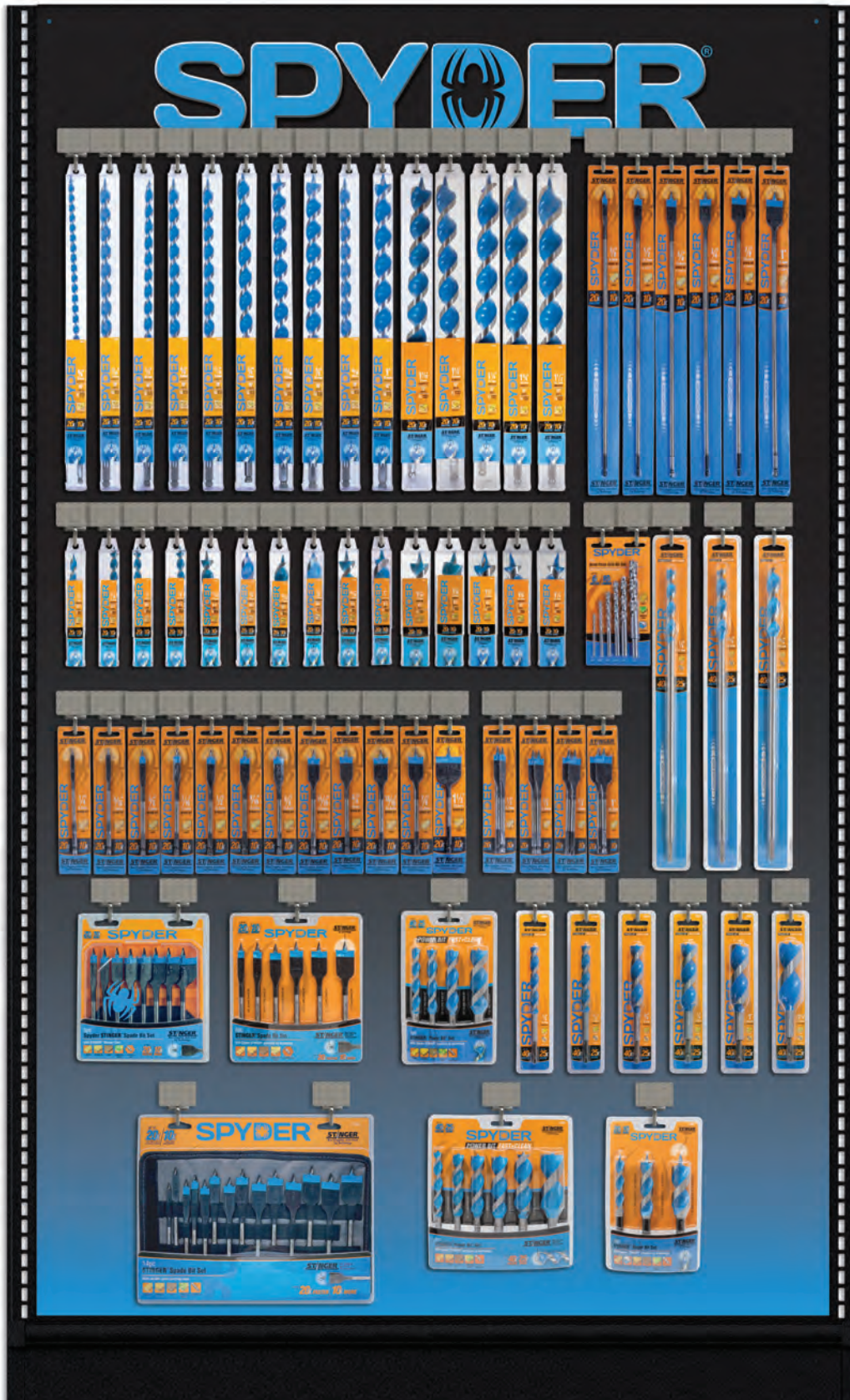

COMPLETE WOOD BORING BIT ASSORTMENT (CONTINUED)

900832

Item#	Description	QTY
900760	4ft Spyder Gondola Graphic Backpanel	1
900712	4in METAL WIRE SCAN HOOKS .225IN DIA THICK	75
900520	REORDER BACKCARDS	75
11001	SPY 14-PC SPADE BIT SET W/POUCH	2
11002	SPY 6-PC SPADE BIT SET	2
11026	SPY 8-PC SPADE BIT SET WITH HARD CASE	2
11003	SPY Stinger Spade Bit 1/4" X 6"	2
11004	SPY Stinger Spade Bit 5/16" X 6"	2
11005	SPY Stinger Spade Bit 3/8" X 6"	2
11006	SPY Stinger Spade Bit 7/16" X 6"	2
11007	SPY Stinger Spade Bit 1/2" X 6"	2
11008	SPY Stinger Spade Bit 9/16" X 6"	2
11009	SPY Stinger Spade Bit 5/8" X 6"	2
11010	SPY Stinger Spade Bit 11/16" X 6"	2
11011	SPY Stinger Spade Bit 3/4" X 6"	2
11012	SPY Stinger Spade Bit 13/16" X 6"	2
11013	SPY Stinger Spade Bit 7/8" X 6"	2
11014	SPY Stinger Spade Bit 15/16" X 6"	2
11015	SPY Stinger Spade Bit 1" X 6"	2
11016	SPY Stinger Spade Bit 1-1/8" X 6"	2
11017	SPY Stinger Spade Bit 1-1/4" X 6"	2
11018	SPY Stinger Spade Bit 1-3/8" X 6"	2
11019	SPY Stinger Spade Bit 1-1/2" X 6"	2
11029	SPY Stinger Spade Bit 1/2" X 6" - 2PK	2
11030	SPY Stinger Spade Bit 5/8" X 6" - 2PK	2
11031	SPY Stinger Spade Bit 3/4" X 6" - 2PK	2
11033	SPY Stinger Spade Bit 1" X 6" - 2PK	2
11020	SPY Stinger Spade Bit 3/8" X 16"	2
11021	SPY Stinger Spade Bit 1/2" X 16"	2
11022	SPY Stinger Spade Bit 5/8" X 16"	2
11023	SPY Stinger Spade Bit 3/4" X 16"	2
11024	SPY Stinger Spade Bit 7/8" X 16"	2
11025	SPY Stinger Spade Bit 1" X 16"	2
11035	SPY STINGER 6PC BRAD POINT SET	2
12001	SPY 3-PC 6-IN AUGER BIT SET	2
12002	SPY 3/8-in X 6-1/2-IN AUGER BIT	2
12031	SPY 7/16-in X 6-1/2-IN AUGER BIT	2
12003	SPY 1/2-in X 6-1/2-IN AUGER BIT	2

Item#	Description	QTY
12004	SPY 5/8-in X 6-1/2-IN AUGER BIT	2
12005	SPY 11/16-in X 6-1/2-IN AUGER BIT	2
12006	SPY 3/4-in X 6-1/2-IN AUGER BIT	2
12007	SPY 13/16-in X 6-1/2-IN AUGER BIT	2
12008	SPY 7/8-in X 6-1/2-IN AUGER BIT	2
12009	SPY 15/16-in X 6-1/2-IN AUGER BIT	2
12010	SPY 1-in X 6-1/2-IN AUGER BIT	2
12011	SPY 1-1/16-in X 6-1/2-IN AUGER BIT	2
12012	SPY 1-1-/8-in X 6-1/2-IN AUGER BIT	2
12013	SPY 1-1/4-in X 6-1/2-IN AUGER BIT	2
12014	SPY 1-3/8-in X 6-1/2-IN AUGER BIT	2
12015	SPY 1-1/2-in X 6-1/2-IN AUGER BIT	2
12016	SPY 3/8-in X 18-IN AUGER BIT	2
12024	SPY 7/16-in X 18-IN AUGER BIT	2
12017	SPY 1/2-in X 18-IN AUGER BIT	2
12018	SPY 5/8-in X 18-IN AUGER BIT	2
12025	SPY 11/16-in X 18-IN AUGER BIT	2
12019	SPY 3/4-in X 18-IN AUGER BIT	2
12026	SPY 13/16-in X 18-IN AUGER BIT	2
12020	SPY 7/8-in X 18-IN AUGER BIT	2
12027	SPY 15/16-in X 18-IN AUGER BIT	2
12021	SPY 1-in X 18-IN AUGER BIT	2
12028	SPY 1-1/16-in X 18-IN AUGER BIT	2
12029	SPY 1-1/8-in X 18-IN AUGER BIT	2
12022	SPY 1-1/4-in X 18-IN AUGER BIT	2
12030	SPY 1-3/8-in X 18-IN AUGER BIT	2
12023	SPY 1-1/2-in X 18-IN AUGER BIT	2
15001	SPY Stinger™ Power Bit™ 4pc Set	2
15003	SPY Stinger™ Power Bit™ 6pc Set	2
15004	SPY 1/2-in X 6-1/2-in Power Bit	2
15005	SPY 5/8-in X 6-1/2-in Power Bit	2
15006	SPY 3/4-in X 6-1/2-in Power Bit	2
15007	SPY 7/8-in X 6-1/2-in Power Bit	2
15008	SPY 1-in X 6-1/2-in Power Bit	2
15012	SPY 1-1/4-in X 6-1/2-in Power Bit	2
15009	SPY 1/2-in X 16-in Power Bit	2
15010	SPY 5/8-in X 16-in Power Bit	2
15011	SPY 3/4-in X 16-in Power Bit	2

32-IN WOOD-METAL DRILLING ROLLING FLOORSTAND DISPLAY

900690

Item#	Description	QTY
900585	SPYDER ROLLING DISPLAY PEGBOARD 32IN X 60IN BLACK	1
900586	SPYDER ROLLING DISPLAY BASE	1
900576	SPYDER ROLLING DISPLAY BRAND HEADER	1
900712	4in METAL WIRE SCAN HOOKS .225IN DIA THICK	106
900520	REORDER BACKCARDS	106
900709-COUNTER	Mach-Blue Goo Cutting Lubricant, 6oz Counter	1
19017	SPY 10pc Mach-Blue Hex Shank Drill Bit Set	2
19031	SPY 15-Piece Drill and Impact Set	2
19032	SPY 30-Piece Drill and Impact Set	2
19000	1/16" Mach-Blue Hex Shank Drill Bit	2
19001	5/64" Mach-Blue Hex Shank Drill Bit	2
19002	3/32" Mach-Blue Hex Shank Drill Bit	2
19003	7/64" Mach-Blue Hex Shank Drill Bit	2
19004	1/8" Mach-Blue Hex Shank Drill Bit	2
19005	9/64" Mach-Blue Hex Shank Drill Bit	2
19006	5/32" Mach-Blue Hex Shank Drill Bit	2
19007	11/64" Mach-Blue Hex Shank Drill Bit	2
19008	3/16" Mach-Blue Hex Shank Drill Bit	2
19009	13/64" Mach-Blue Hex Shank Drill Bit	2
19010	7/32" Mach-Blue Hex Shank Drill Bit	2
19011	15/64" Mach-Blue Hex Shank Drill Bit	2
19012	1/4" Mach-Blue Hex Shank Drill Bit	2
19013	5/16" Mach-Blue Hex Shank Drill Bit	2
19014	3/8" Mach-Blue Hex Shank Drill Bit	2
19015	7/16" Mach-Blue Hex Shank Drill Bit	2
19016	1/2" Mach-Blue Hex Shank Drill Bit	2
19025	2pc Step Bit Set, Mach-Blue Hex Shank, (1/8"-1/2" & 3/16"-7/8")	3
19019	SPY 13 Step Bit, Mach-Blue Hex Shank, 1/8" - 1/2" #1	3
19020	SPY 6 Step Bit, Mach-Blue Hex Shank, 3/16" - 1/2"	3
19021	SPY 9 Step Bit, Mach-Blue Hex Shank, 1/4" - 3/4"	3
19022	SPY 12 Step Bit, Mach-Blue Hex Shank, 3/16" - 7/8" #4	3
19023	SPY 16 Step Bit, Mach-Blue Hex Shank, 3/16" - 1-1/8"	3
19024	SPY 10 Step Bit, Mach-Blue Hex Shank, 1/4" - 1-3/8"	3
19071	SPY 8 Step Bit, Mach-Blue Hex Shank, 1/4" - 1"	3
11001	SPY 14-PC SPADE BIT SET W/POUCH	2
11002	SPY 6-PC SPADE BIT SET	2
11026	SPY 8-PC SPADE BIT SET WITH HARD CASE	2
11003	SPY Stinger Spade Bit 1/4" X 6"	2
11004	SPY Stinger Spade Bit 5/16" X 6"	2
11005	SPY Stinger Spade Bit 3/8" X 6"	2
11006	SPY Stinger Spade Bit 7/16" X 6"	2
11007	SPY Stinger Spade Bit 1/2" X 6"	2
11008	SPY Stinger Spade Bit 9/16" X 6"	2



Double-Sided Display Front

32-IN WOOD-METAL DRILLING ROLLING FLOORSTAND DISPLAY (CONTINUED)

900690

Item#	Description	QTY
11009	SPY Stinger Spade Bit 5/8" X 6"	2
11010	SPY Stinger Spade Bit 11/16" X 6"	2
11011	SPY Stinger Spade Bit 3/4" X 6"	2
11012	SPY Stinger Spade Bit 13/16" X 6"	2
11013	SPY Stinger Spade Bit 7/8" X 6"	2
11014	SPY Stinger Spade Bit 15/16" X 6"	2
11015	SPY Stinger Spade Bit 1" X 6"	2
11016	SPY Stinger Spade Bit 1-1/8" X 6"	2
11017	SPY Stinger Spade Bit 1-1/4" X 6"	2
11018	SPY Stinger Spade Bit 1-3/8" X 6"	2
11019	SPY Stinger Spade Bit 1-1/2" X 6"	2
11029	SPY Stinger Spade Bit 1/2" X 6" - 2PK	2
11030	SPY Stinger Spade Bit 5/8" X 6" - 2PK	2
11031	SPY Stinger Spade Bit 3/4" X 6" - 2PK	2
11033	SPY Stinger Spade Bit 1" X 6" - 2PK	2
11020	SPY Stinger Spade Bit 3/8" X 16"	2
11021	SPY Stinger Spade Bit 1/2" X 16"	2
11022	SPY Stinger Spade Bit 5/8" X 16"	2
11023	SPY Stinger Spade Bit 3/4" X 16"	2
11024	SPY Stinger Spade Bit 7/8" X 16"	2
11025	SPY Stinger Spade Bit 1" X 16"	2
11035	SPY STINGER 6PC BRAD POINT SET	2
12001	SPY 3-PC 6-IN AUGER BIT SET	2
12002	SPY 3/8-in X 6-1/2-IN AUGER BIT	2
12031	SPY 7/16-in X 6-1/2-IN AUGER BIT	2
12003	SPY 1/2-in X 6-1/2-IN AUGER BIT	2
12004	SPY 5/8-in X 6-1/2-IN AUGER BIT	2
12005	SPY 11/16-in X 6-1/2-IN AUGER BIT	2
12006	SPY 3/4-in X 6-1/2-IN AUGER BIT	2
12007	SPY 13/16-in X 6-1/2-IN AUGER BIT	2
12008	SPY 7/8-in X 6-1/2-IN AUGER BIT	2
12009	SPY 15/16-in X 6-1/2-IN AUGER BIT	2
12011	SPY 1-1/16-in X 6-1/2-IN AUGER BIT	2
12012	SPY 1-1/8-in X 6-1/2-IN AUGER BIT	2
12013	SPY 1-1/4-in X 6-1/2-IN AUGER BIT	2
12014	SPY 1-3/8-in X 6-1/2-IN AUGER BIT	2
12015	SPY 1-1/2-in X 6-1/2-IN AUGER BIT	2
12016	SPY 3/8-in X 18-IN AUGER BIT	2
12024	SPY 7/16-in X 18-IN AUGER BIT	2
12017	SPY 1/2-in X 18-IN AUGER BIT	2
12018	SPY 5/8-in X 18-IN AUGER BIT	2
12025	SPY 11/16-in X 18-IN AUGER BIT	2
12019	SPY 3/4-in X 18-IN AUGER BIT	2



*Double-Sided
Display Back*

32-IN WOOD-METAL DRILLING ROLLING FLOORSTAND DISPLAY (CONTINUED)

900690

Item#	Description	QTY
12026	SPY 13/16-in X 18-IN AUGER BIT	2
12020	SPY 7/8-in X 18-IN AUGER BIT	2
12027	SPY 15/16-in X 18-IN AUGER BIT	2
12021	SPY 1-in X 18-IN AUGER BIT	2
12028	SPY 1-1/16-in X 18-IN AUGER BIT	2
12029	SPY 1-1/8-in X 18-IN AUGER BIT	2
12022	SPY 1-1/4-in X 18-IN AUGER BIT	2
12030	SPY 1-3/8-in X 18-IN AUGER BIT	2
12023	SPY 1-1/2-in X 18-IN AUGER BIT	2
15001	SPY STINGER POWER BIT 4pc Set	2
15003	SPY STINGER POWER BIT 6pc Set	2
15004	SPY 1/2-in X 6-1/2-in POWER BIT	2
15005	SPY 5/8-in X 6-1/2-in POWER BIT	2
15006	SPY 3/4-in X 6-1/2-in POWER BIT	2
15007	SPY 7/8-in X 6-1/2-in POWER BIT	2
15008	SPY 1-in X 6-1/2-in POWER BIT	2
15012	SPY 1-1/4-in X 6-1/2-in POWER BIT	2
15009	SPY 1/2-in X 16-in POWER BIT	2
15010	SPY 5/8-in X 16-in POWER BIT	2
15011	SPY 3/4-in X 16-in POWER BIT	2



3X3™ DOUBLE-SIDED RECIPROCATING SAW BLADES

- Double-edged blade cuts in both directions without needing to flip the saw over
- Rounded tip plunge cuts with ease - no pilot hole needed
- Two-sided blades last up to **20x longer** than conventional single-sided blades
- Shatter resistant 8% cobalt Bi-Metal blade.
- Cuts wood, pipe, sheet metal, plastic, fiberglass and more.
- Cost effective - 2 blades for the price of one!
- Made in Germany.



UP TO **20x** LONGER

LINEAR EDGE



Plunge Cut with Ease.

Shatter Resistant 8% Cobalt Bi-Metal Blade.



9PC 3X3™ DOUBLE-SIDED RECIP BLADES

200326

Item#	Description	QTY
900718	6 Hook Recip Saw Rack	1
900719	3 Hook Recip Saw Rack	1
900520	REORDER BACKCARDS	12
200176	SPY 3X3™ 6x10 TPI - 6" Bulk	10
200177	SPY 3X3™ 6x10 TPI - 8" Bulk	10
200179	SPY 3X3™ 10x14 TPI - 8" Bulk	10
200180	SPY 3X3™ 14x18 TPI - 6" Bulk	10
200203	SPY 3X3™ 10/14 x 14 TPI - Bulk	10
200204	SPY 3X3™ 10/14 x 14 TPI - 10" Bulk	10
200205	SPY 3X3™ 10/14 x 14 TPI - 8" Bulk	10
200206	SPY 3X3™ 8/12 x 10 TPI - 8" Bulk	10
200207	SPY 3X3™ 8/12 x 10 TPI - 10" Bulk	10
200228	SPY 5pc 3X3™ Reciprocating Saw Blade Kit	6

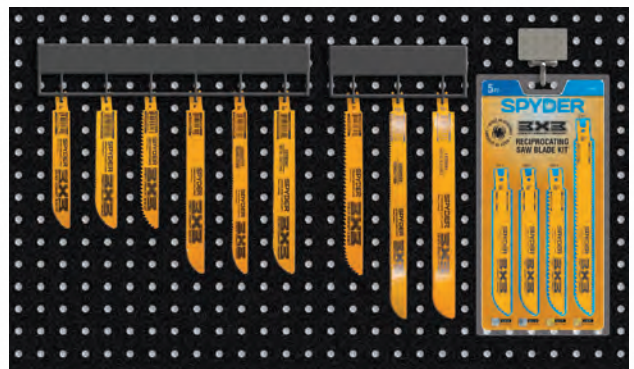

3X3™ DOUBLE-SIDED RECIP SAW BLADE COUNTER DISPLAY

200329

LINEAR EDGE

Item#	Description	QTY
200227	Reciprocating Saw Blade Counter Display	1
900520	REORDER BACKCARDS	2
200176	SPY 3X3 6x10 TPI - 6" Bulk	10
200177	SPY 3X3™ 6x10 TPI - 8" Bulk	10
200179	SPY 3X3™ 10x14 TPI - 8" Bulk	10
200180	SPY 3X3™ 14x18 TPI - 6" Bulk	10
200203	SPY 3X3™ 10/14 x 14 TPI - Bulk	10
200204	SPY 3X3™ 10/14 x 14 TPI - 10" Bulk	20
200205	SPY 3X3™ 10/14 x 14 TPI - 8" Bulk	10
200206	SPY 3X3™ 8/12 x 10 TPI - 8" Bulk	20
200207	SPY 3X3™ 8/12 x 10 TPI - 10" Bulk	20
200228	SPY 5pc 3X3™ Reciprocating Saw Blade Kit	6

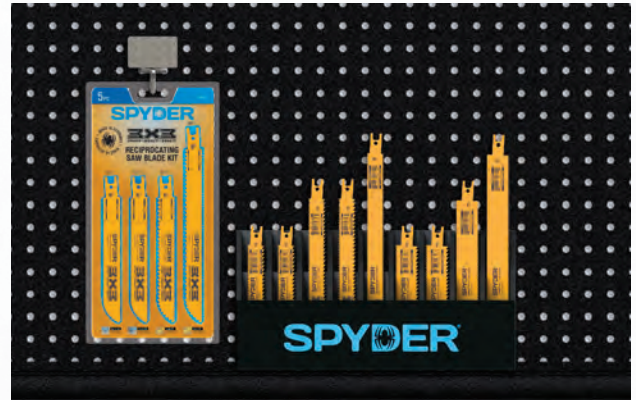

Fixture view for example use only



MACH-BLUE™ RECIPROCATING SAW BLADES

Mach-Blue™ Plating & 8% Cobalt Bi-Metal Construction for Increased Durability in Tough Applications

- Up to **20x longer lasting** than conventional bi-metal blades.
- Super hard proprietary Mach-Blue™ plating retains sharper cutting edges for fast and accurate cutting.
- Shatter-resistant bi-metal blade is designed to bend and flex for added safety.
- Variable tooth pitch guarantees fast and clean cuts through a wide variety of materials.
- Extreme value when compared to more expensive carbide tipped reciprocating saw blades.
- Cuts wood with nails, steel, PVC and more.
- Made in Germany.



UP TO
20x
LONGER



8% Cobalt Teeth

MACH-BLUE™ RECIP SAW BLADES

200328

Item#	Description	QTY
900520	REORDER BACKCARDS	7
200319	Mach-Blue 6" 10/14 TPI Recip Blade - 2 Pack	2
200320	Mach-Blue 6" 18TPI Recip Blade 2 Pack	2
200321	Mach-Blue 9-IN 6TPI Recip Blade - 2 Pack	2
200322	Mach-Blue 9-IN 10/14TPI Recip Blade - 2 Pack	2
200323	Mach-Blue 12-IN 6TPI Recip Blade - 2 Pack	2
200324	Mach-Blue 12-IN 10/14TPI Recip Blade - 2 Pack	2

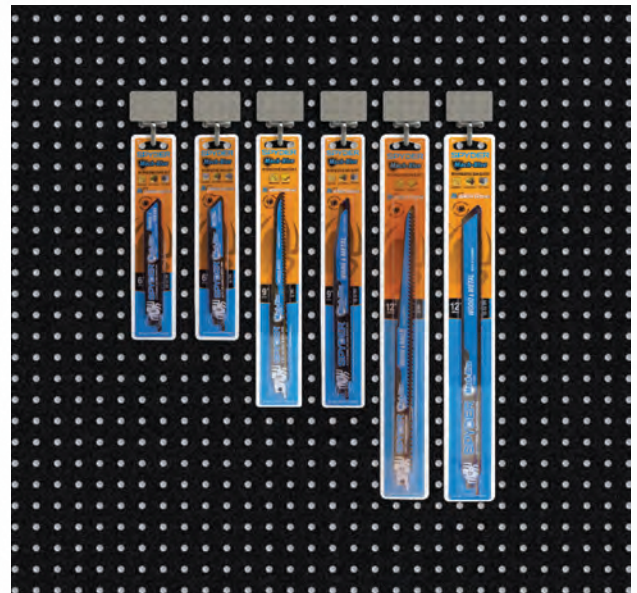

LINEAR EDGE

BLACK SERIES™ BI-METAL RECIPROCATING SAW BLADES

Variable Tooth Pitch Guarantees Fast and Clean Cuts through Various Material Thicknesses

- Up to **10x longer lasting** than conventional bi-metal blades.
- Up to **3x faster** than conventional bi-metal blades.
- 8% cobalt teeth provide exceptionally long cutting durability and heat resistance.
- Shatter-resistant and durable for the toughest cutting applications.
- Cuts steel, stainless steel, aluminum, wood with nails, PVC and more.
- Made in the USA



Shatter-Resistant and Durable

8% Cobalt Teeth

BLACK SERIES™ BI-METAL RECIP BLADES

200327

Item#	Description	QTY
900520	REORDER BACKCARDS	8
200302	SPY Black Series Bi-Metal Recip, 10/14 TPI, 6" - 5 Pack	2
200303	SPY Black Series Bi-Metal Recip, 18 TPI, 6" - 5 Pack	2
200304	SPY Black Series Bi-Metal Recip, 6 TPI, 9" - 5 Pack	2
200305	SPY Black Series Bi-Metal Recip, 10/14 TPI, 9" - 5 Pack	2
200306	SPY Black Series Bi-Metal Recip, 6 TPI, 12" - 3 Pack	2
200307	SPY Black Series Bi-Metal Recip, 10/14 TPI, 12" - 3 Pack	2
200308	SPY Black Series Bi-Metal Recip, 14pc recip Kit	2



LINEAR EDGE

TUNGSTEN CARBIDE TIPPED (TCT) RECIPROCATING SAW BLADES

Cuts with Significantly Less Dust & Debris than Conventional Rotary Cutting Wheels

- Quickly cuts through concrete block, brick, masonry and timber.
- Creates less dust & debris than conventional rotary wheels.
- Tungsten carbide tipped blade provides extended tool life.
- Make square & flush cuts.
- Access hard-to-reach areas.
- 9", 12" and 18" lengths.
- Made in Germany.

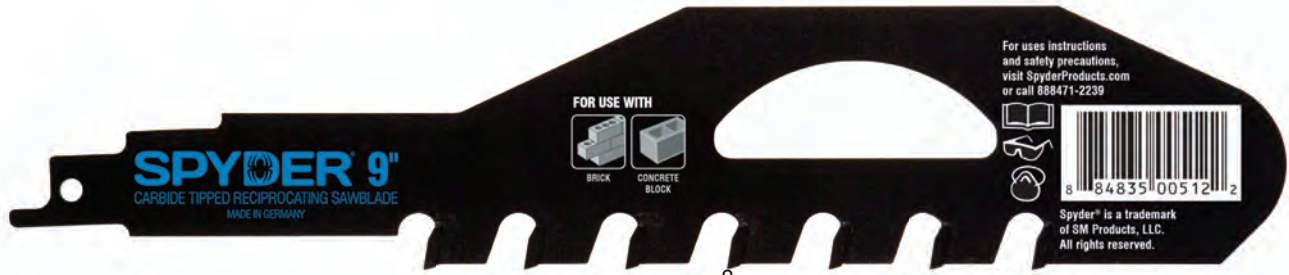
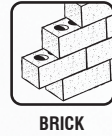
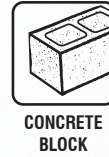

Tungsten Carbide Tipped for Extended Life and Clean Cuts.

TCT RECIP SAW BLADES

200325

Item#	Description	QTY
900719	3 Hook Recip Saw Wire Rack	1
900520	REORDER BACKCARDS	4
200209	SPY TCT Recip Blade - 9"	2
200210	SPY TCT Recip Blade - 12"	2
200211	SPY TCT Recip Blade - 18"	2

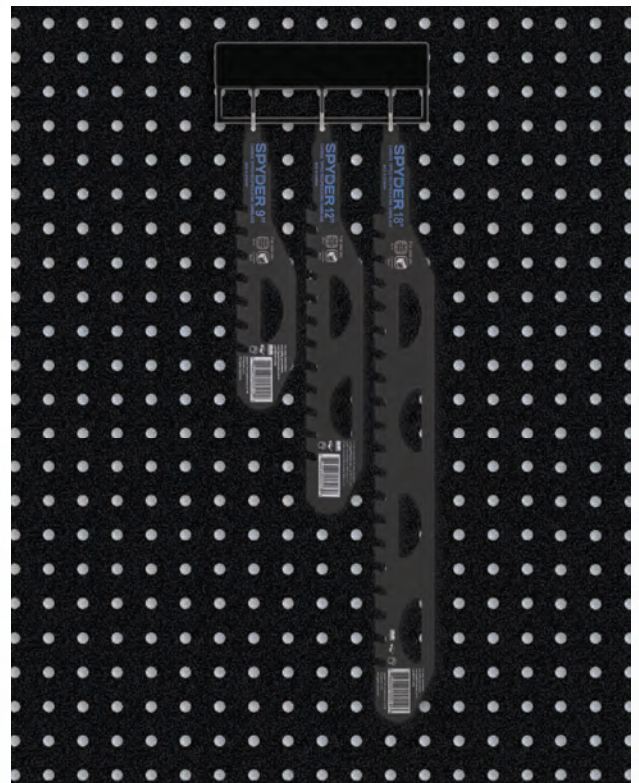

LINEAR EDGE

JIG SAW BLADES

Fast and Clean Cuts through Wood

- Skeleton™ open framework design creates exceptionally straight cuts and blades dissipate frictional heat for extreme durability.
- Double-Sided blades cut forward, backward, and pivot like a scroll saw to make tight curve cuts.
- Blade types include: Fast Straight, Clean Straight, Clean Straight Down, Fast Curve and Clean Curve.
- Blade lengths include: 3-1/2", 4" and 4-1/2".
- Made in Germany.

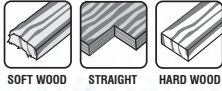

SKELETON™



Skeleton™ Open Framework Design Creates Exceptionally Straight Cuts.



Down Cut Creates Cleaner Top Cuts.

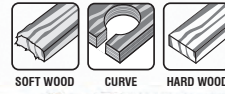

DOUBLE-SIDED™



Double-Sided Blades Create Precise, Small Curve Cuts.

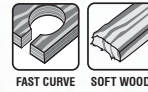

Aggressive teeth for fast curves

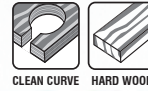

Neutral grind for clean curves



EVERYDAY JIG SAW BLADES

300103

Item#	Description	QTY
900520	REORDER BACKCARDS	24
300037	SPY Jig Saw, 2-Side & Skeleton Wood Cutting CRV, 8pc	2
300002	DOUBLE SIDED JIGSAW 4.5" - 2PC WOOD	2
300004	DOUBLE SIDED JIGSAW 4" - 2PC MULTI SURFACE	2
300009	DOUBLE SIDED JIGSAW - 2PC COMBO SET	2
300012	SKELETON JIGSAW 4" - 2PC NEUTRAL/CLEAN	2
300020	SKELETON JIGSAW - 2PC COMBO SET	2
300022	SKELETON JIGSAW 4" - 2PC HARD & SOFT WOOD	2
300061	5pc Jigsaw Wood Set	2
300062	5pc Jigsaw Multi Set	2
300063	5pc Jigsaw Metal Set	2
300064	10pc Jigsaw, Wood/Metal Set	2
300065	12pc Jigsaw Dbl, Skeleton, Wood, Metal Set	2
300088	SPY Jig Saw Set on card, Laminate Cutting, BIM, 5pc	2
300089	SPY Jig Saw Set on card, Laminate Cutting, BIM, 5pc	2
300090	SPY Jig Saw Set with Case, Multi-Material Cutting, 10pc	2
300091	SPY Jig Saw Set with case, Multi-Material Cutting, 20pc	2
300097	SPY Jig Saw, Set with Case, Wood Cutting CRV, 8pc	2
300098	SPY Jig Saw, Wood & Metal Cutting BIM, 6/10 TPI, 3pc	2
300099	SPY Jig Saw, 2-Side Wood Cutting CRV, 8/11 TPI, 2pc	2
300100	SPY Jig Saw, 2-Side Wood Cutting CRV, 10/18 TPI, 2pc	2
300101	SPY Jig Saw, Skeleton Wood Cutting CRV, 10 TPI, 2pc	2
300102	SPY Jig Saw, Skeleton Wood Cutting CRV, 17 TPI, 2pc	2

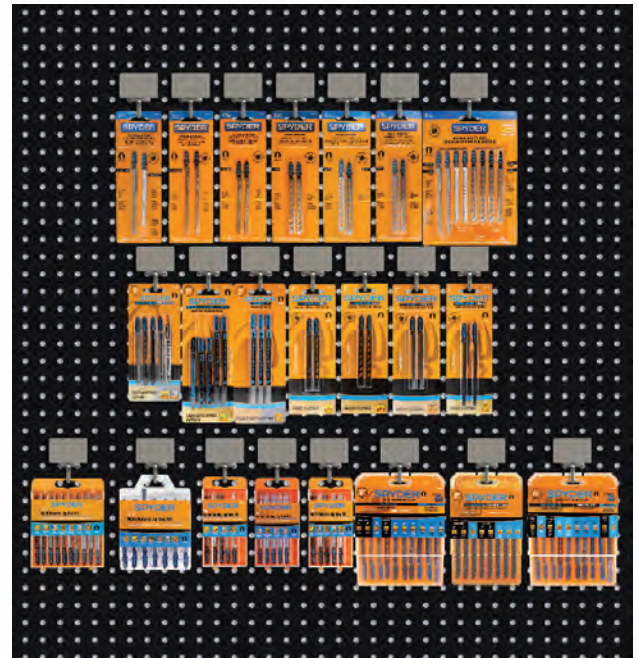

LINEAR EDGE

PRO POWERED TOOLS

STREAMLINED JIG SAW BLADES

300104

Item#	Description	QTY
900520	REORDER BACKCARDS	13
300061	5pc Jigsaw Wood Set	2
300062	5pc Jigsaw Multi Set	2
300063	5pc Jigsaw Metal Set	2
300064	10pc Jigsaw, Wood/Metal Set	2
300065	12pc Jigsaw Dbl, Skeleton, Wood, Metal Set	2
300002	DOUBLE SIDED JIGSAW 4.5" - 2PC WOOD	2
300004	DOUBLE SIDED JIGSAW 4" - 2PC MULTI SURFACE	2
300009	DOUBLE SIDED JIGSAW - 2PC COMBO SET	2
300012	SKELETON JIGSAW 4" - 2PC NEUTRAL/CLEAN	2
300022	SKELETON JIGSAW 4" - 2PC HARD & SOFT WOOD	2
300020	SKELETON JIGSAW - 2PC COMBO SET	2
300037	8PC VARIETY PACK T-SHANK BLADES	2

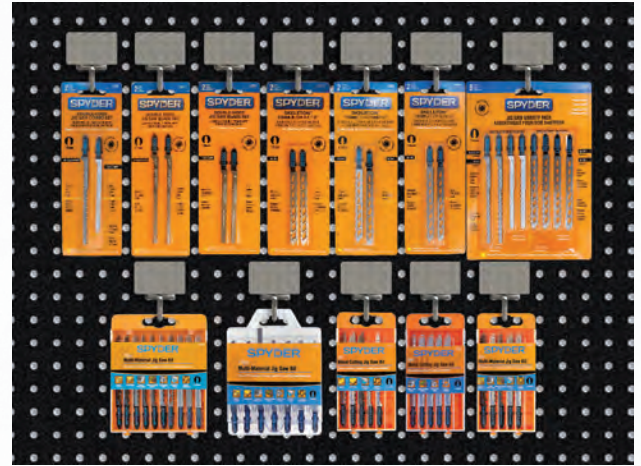

LINEAR EDGE



SPYDER® RECIPROCATING ACCESSORIES

CARBON STEEL WIRE RECIPROCATING BRUSH

Fits Where Many Rotary Brushes Cannot

- Use on metals, concrete, stone and wood surfaces.
- Tough carbon steel bristles remove the toughest contaminants.
- Removes flaking paint, rust, scratches, dirt and small imperfections.
- Fits all reciprocating saws.

SPYDER® SCRAPER™ RECIPROCATING BLADES

Finish the Job in a Fraction of the Time with a Fraction of the Effort

- Easily remove tile, linoleum flooring, mastics and more.
- Quenched and tempered high-carbon spring steel retains edge sharpness.
- Re-sharpenable blade extends tool life.
- Multiple applications.
- Fits all reciprocating saws.
- Made in the USA.

GROUT-OUT™ RECIPROCATING BLADES

Provides Both Speed and Precision to Make Your Job Easy

- Up to 10x faster than hand removal.
- Vacuum-braided tungsten carbide grit quickly removes grout.
- Power through any grout in a fraction of the time – including urethane and epoxy.
- Fits all reciprocating saws.

SANDER

Tight Spaces, Curved Surfaces and Hard-to-Reach Corners

- Quickly sand tight spaces, curved surfaces and outside and inside corners.
- Tough insert-molded attachment blade provides maximum durability.
- Hook-and-loop sandpaper is quick and easy to replace.
- 3 piece sandpaper set included.
- Compatible with Mouse™ sandpaper.
- Fits all reciprocating saws.

NYLON RECIPROCATING BRUSH

Makes Clean-Up and Surface Prep a Snap

- Use on grout, carpet, tile, laminates, rubber, concrete, brick and more.
- Nylon bristles provide tough cleaning power without scratching surfaces.
- Makes quick work of stubborn layers of grime.
- Fits all reciprocating saws.

RECIP ACCESSORIES PACKAGED

900843

Item#	Description	QTY
900520	REORDER BACKCARDS	11
138	SPY Scraper Skin Pack 2"	2
108	SPY Scraper Skin Pack 4"	2
137	SPY Scraper Skin Pack 6"	2
243	SPY Scraper Stacked Multi-Blade Skin Pack, 2,4,6in	2
100227	SPY Grout-Out 1/16 - 3/16 Skin Pack	2
100231	SPY Grout-Out 3/16+ Skin Pack	2
100234	SPY Grout-Out 2PC Skin Multi Pack	2
400002	SPY Wire Brush 4.5" Packaged	2
400004	SPY Nylon Brush 4.5" Packaged	2
500010	SPY Corner Sanding Kit	2



PRO POWERED TOOLS

SMALL RECIPROCATING ACCESSORIES WIRE RACK

900828

Item#	Description	QTY
900717	8pc Recip Accessory Rack	1
900840	8pc Recip Backer Card	1
900520	REORDER BACKCARD	12
319	SPY Scraper 2" BULK - with barcode printed on back	2
320	SPY Scraper 4" BULK - with barcode printed on back	2
321	SPY Scraper 6" BULK - with barcode printed on back	2
243	SPY Scraper Stacked Multi-Blade Skin Pack, 2,4,6in	2
100263	SPY Grout-Out™ Narrow Single - Bulk w/ UPC	2
100264	SPY Grout-Out™ Wide Single - Bulk w/ UPC	2
400005	SPY Wire Brush - Bulk with UPC	2
400006	SPY Nylon Brush - Bulk with UPC	2
500010	SPY Recip Sander w/ Sandpaper	2
100234	SPY Spyder Grout-Out Multi-Pack	2



LINEAR EDGE



Fixture View

LARGE RECIPROCATING ACCESSORIES WIRE RACK

900829

Item#	Description	QTY
900471	14pc Recip Accessories	1
900839	EVERYDAY 14pc Recip Backer Card	1
900520	REORDER BACKCARDS	15
319	SPY Scraper 2" Bulk - with barcode printed on back	2
320	SPY Scraper 4" Bulk - with barcode printed on back	2
321	SPY Scraper 6" Bulk - with barcode printed on back	2
243	SPY Scraper Stacked Multi-Blade Skin Pack, 2,4,6in	2
100263	SPY Grout-Out™ Narrow Single - Bulk w/ UPC	2
100264	SPY Grout-Out™ Wide Single - Bulk w/ UPC	2
400005	SPY Wire Brush - Bulk with UPC	2
400006	SPY Nylon Brush - Bulk with UPC	2
200176	SPY 3X3™ - 6x10 TPI - 6"	10
200177	SPY 3X3™ - 6x10 TPI - 8"	10
200179	SPY 3X3™ - 10x14 TPI - 8"	10
200180	SPY 3X3™ - 14x18 TPI - 6"	10
200204	SPY 3X3™ - 10/14x14 TPI - 10" Extreme Metal	10
200207	SPY 3X3™ - 8/12x10 TPI - 10" Advanced Demo	10



Fixture View

SPYDER® OSCILLATING TOOL BLADES

- Make up to **60x more cuts** than standard Bi-Metal blades for increased service life in demanding plunge and lateral cuts in wood, nails, screws, PVC, drywall and more.
- A universal fit arbor ensures compatibility with all open-back oscillating tool motors.
- A full 2" depth of cut on each blade ensures maximum reach and superior cutting tooth velocity.
- Bi-Metal blades feature an 8% cobalt bi-metal cutting edge that resists high cutting heat and these blades are dual/ tri-plated for additional friction reduction and edge retention.
- High speed steel blades feature a Japanese-tooth cutting geometry that makes the cleanest cuts in soft and hard woods.
- These blades are not compatible with Starlock™ tools.

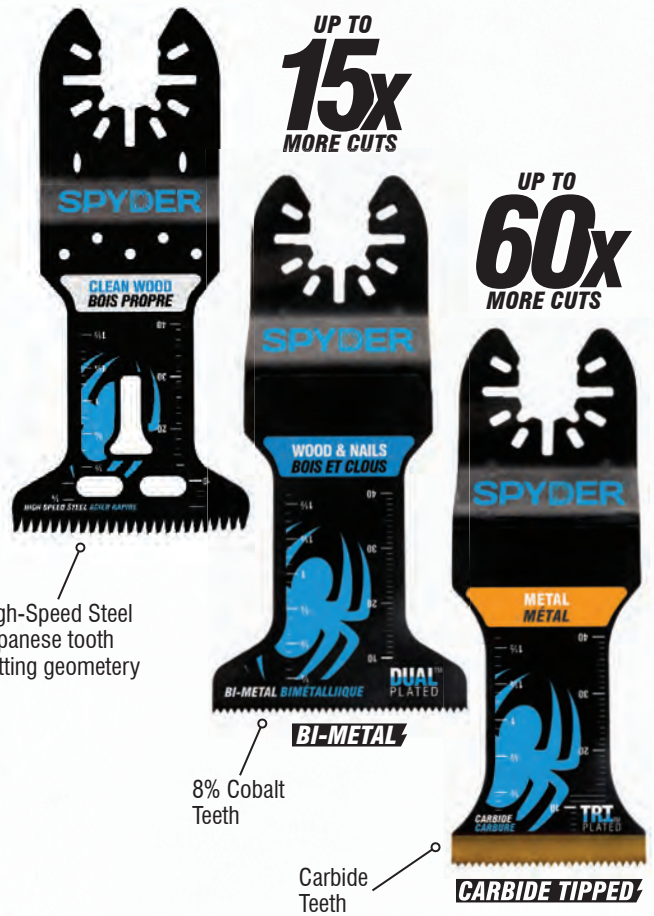

AVAILABLE IN MARCH 2024



WOOD/NAILS



PLASTIC/PVC

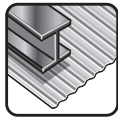

ALL METAL

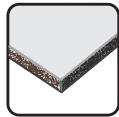

DRY WALL

OSCILLATING TOOL BLADES

70100

Item#	Description	QTY
900520	REORDER BACKCARDS	9
70000	SPY OMT 5PC KIT BIM/HSS	3
70004	SPY OMT Wood Nails, 1-3/8-in BIM 1pc	3
70005	SPY OMT Wood Nails, 1-3/4-in BIM 1pc	3
70006	SPY OMT Wood Nails, 2-1/2-in BIM 1pc	3
70008	SPY OMT Clean Wood, 1-3/4-in HSS 1pc	3
70009	SPY OMT Clean Wood, 2-1/2-in HSS 1pc	3
70012	SPY OMT Metal, 1-1/4-in BIM 1pc	3
70013-3	SPY OMT Metal, 1-3/8-in CARBIDE 3pc	3

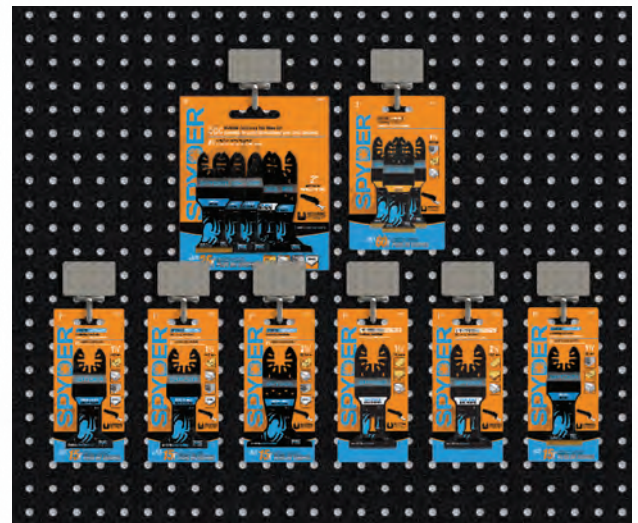

PRO POWERED TOOLS

32-IN LINEAR EDGE ROLLING FLOORSTAND DISPLAY

900837

Item#	Description	QTY
900585	SPYDER ROLLING DISPLAY PEGBOARD 32IN X 60IN BLACK	1
900586	SPYDER ROLLING DISPLAY BASE	1
900576	SPYDER ROLLING DISPLAY BRAND HEADER	1
900712	4in METAL WIRE SCAN HOOKS .225IN DIA THICK	30
900520	REORDER BACKCARDS	50
900718	6 Hook Recip Saw Rack	2
900717	8pc Recip Accessory Rack	1
900840	Recip Backer Card	1
243	SPY Scraper Stacked Multi-Blade Skin Pack, 2,4,6in	2
319	SPY Scraper 2" BULK - wth barcode printed on back	2
320	SPY Scraper 4" BULK - with barcode printed on back	2
321	SPY Scraper 6" BULK - with barcode printed on back	2
100263	SPY Grout-Out™ Narrow Single - Bulk w/ UPC	2
100264	SPY Grout-Out™ Wide Single - Bulk w/ UPC	2
200176	SPY 3X3™ 6x10 TPI - 6" Bulk	10
200177	SPY 3X3™ 6x10 TPI - 8" Bulk	10
200179	SPY 3X3™ 10x14 TPI - 8" Bulk	10
200180	SPY 3X3™ 14x18 TPI - 6" Bulk	10
200203	SPY 3X3™ 10/14 x 14 TPI - Bulk	10
200204	SPY 3X3™ 10/14 x 14 TPI - 10" Bulk	10
200205	SPY 3X3™ 10/14 x 14 TPI - 8" Bulk	10
200206	SPY 3X3™ 8/12 x 10 TPI - 8" Bulk	10
200207	SPY 3X3™ 8/12 x 10 TPI - 10" Bulk	10
200209	SPY TCT Recip Blade - 9"	2
200210	SPY TCT Recip Blade - 12"	2
200211	SPY TCT Recip Blade - 18"	2
200228	SPY 5pc 3X3™ Reciprocating Saw Blade Kit	6
200302	SPY Black Series Bi-Metal Recip, 10/14 TPI, 6" - 5 Pack	2
200303	SPY Black Series Bi-Metal Recip, 18 TPI, 6" - 5 Pack	2
200304	SPY Black Series Bi-Metal Recip, 6 TPI, 9" - 5 Pack	2
200305	SPY Black Series Bi-Metal Recip, 10/14 TPI, 9" - 5 Pack	2
200306	SPY Black Series Bi-Metal Recip, 6 TPI, 12" - 3 Pack	2
200307	SPY Black Series Bi-Metal Recip, 10/14 TPI, 12" - 3 Pack	2
200308	SPY Black Series Bi-Metal Recip, 14pc recip Kit	2
200319	Mach-Blue 6" 10/14 TPI Recip Blade - 2 Pack	2
200320	Mach-Blue 6" 18TPI Recip Blade 2 Pack	2
200321	Mach-Blue 9-IN 6TPI Recip Blade - 2 Pack	2
200322	Mach-Blue 9-IN 10/14TPI Recip Blade - 2 Pack	2
200323	Mach-Blue 12-IN 6TPI Recip Blade - 2 Pack	2
200324	Mach-Blue 12-IN 10/14TPI Recip Blade - 2 Pack	2
300002	DOUBLE SIDED JIGSAW 4.5" - 2PC WOOD	2
300004	DOUBLE SIDED JIGSAW 4" - 2PC MULTI SURFACE	2
300009	DOUBLE SIDED JIGSAW - 2PC COMBO SET	2
300012	SKELETON JIGSAW 4" - 2PC NEUTRAL/CLEAN	2



Single-Sided Display

300020	SKELETON JIGSAW - 2PC COMBO SET	2
300022	SKELETON JIGSAW 4" - 2PC HARD & SOFT	2
300037	8PC VARIETY PACK T-SHANK BLADES	2
300061	5pc Jigsaw Wood Set	2
300062	5pc Jigsaw Multi Set	2
300063	5pc Jigsaw Metal Set	2
300064	10pc Jigsaw, Wood/Metal Set	2
300065	12pc Jigsaw Dbl, Skeleton, Wood, Metal Set	2
400005	SPY Wire Brush - Bulk with UPC	2
400006	SPY Nylon Brush - Bulk with UPC	2
500010	SPY Recip Sander w/ Sandpaper	2

COMPLETE LINEAR EDGE ASSORTMENT

900842

LINEAR EDGE

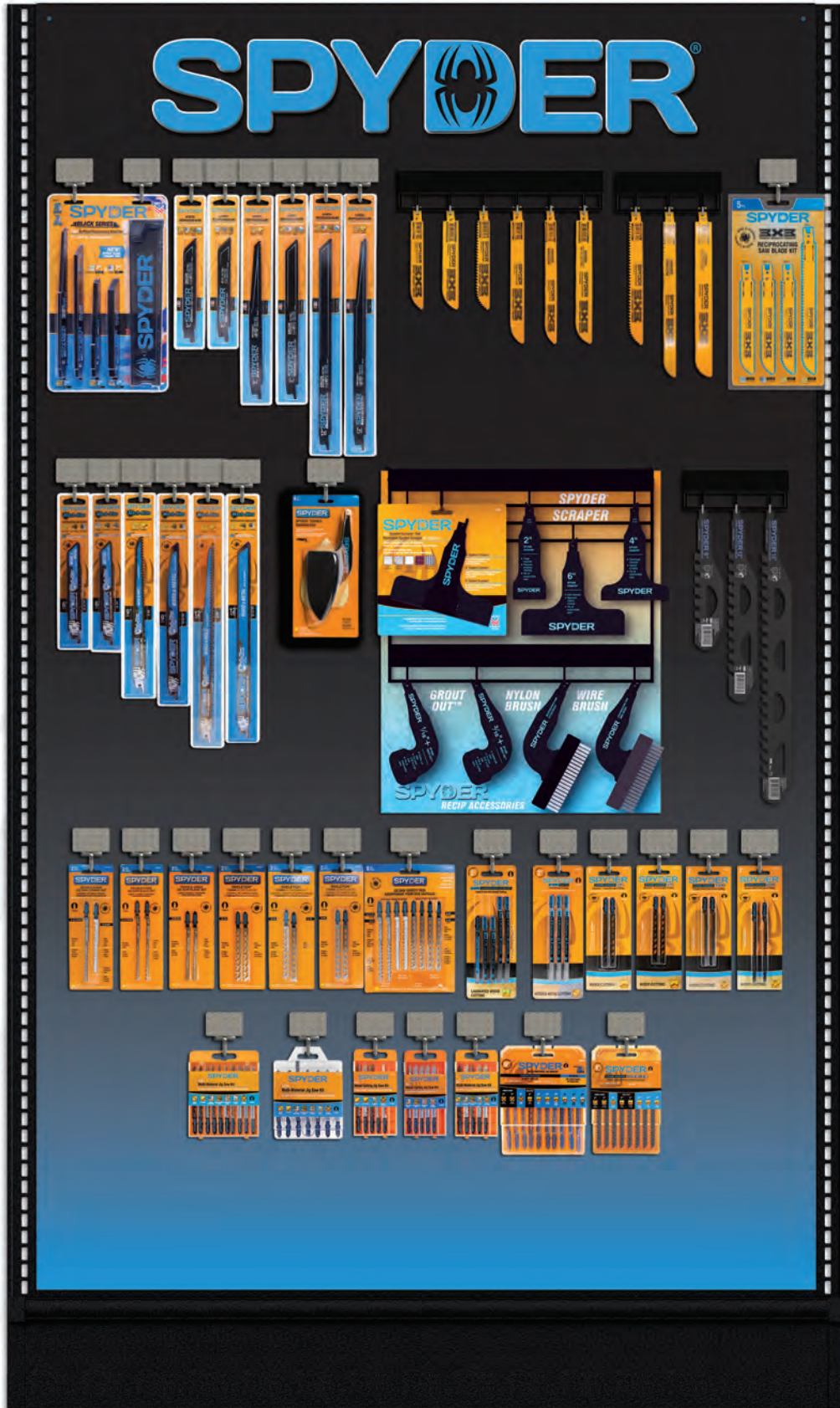

PRO POWERED TOOLS

COMPLETE LINEAR EDGE ASSORTMENT (CONTINUED)

900842

Item#	Description	QTY
900760	4ft Spyder Gondola Graphic Backpanel	1
900712	4in METAL WIRE SCAN HOOKS .225IN DIA THICK	40
900520	REORDER BACKCARDS	60
900718	6 Hook Recip Saw Rack	1
900719	3 Hook Recip Saw Wire Rack	2
900717	8pc Recip Accessory Rack	1
900840	8pc Recip Backer Card	1
319	SPY Scraper 2" BULK - wth barcode printed on back	2
320	SPY Scraper 4" BULK - with barcode printed on back	2
321	SPY Scraper 6" BULK - with barcode printed on back	2
243	SPY Scraper Stacked Multi-Blade Skin Pack, 2,4,6in	2
100263	SPY Grout-Out™ Narrow Single - Bulk w/ UPC	2
100264	SPY Grout-Out™ Wide Single - Bulk w/ UPC	2
400005	SPY Wire Brush - Bulk with UPC	2
400006	SPY Nylon Brush - Bulk with UPC	2
500010	SPY Recip Sander w/ Sandpaper	2
200209	SPY TCT Recip Blade - 9"	2
200210	SPY TCT Recip Blade - 12"	2
200211	SPY TCT Recip Blade - 18"	2
200176	SPY 3X3™ 6x10 TPI - 6" Bulk	10
200177	SPY 3X3™ 6x10 TPI - 8" Bulk	10
200179	SPY 3X3™ 10x14 TPI - 8" Bulk	10
200180	SPY 3X3™ 14x18 TPI - 6" Bulk	10
200203	SPY 3X3™ 10/14 x 14 TPI - Bulk	10
200204	SPY 3X3™ 10/14 x 14 TPI - 10" Bulk	10
200205	SPY 3X3™ 10/14 x 14 TPI - 8" Bulk	10
200206	SPY 3X3™ 8/12 x 10 TPI - 8" Bulk	10
200207	SPY 3X3™ 8/12 x 10 TPI - 10" Bulk	10
200228	SPY 5pc 3X3™ Reciporcatng Saw Blade Kit	6
200302	SPY Black Series Bi-Metal Recip, 10/14 TPI, 6" - 5 Pack	2
200303	SPY Black Series Bi-Metal Recip, 18 TPI, 6" - 5 Pack	2
200304	SPY Black Series Bi-Metal Recip, 6 TPI, 9" - 5 Pack	2
200305	SPY Black Series Bi-Metal Recip, 10/14 TPI, 9" - 5 Pack	2
200306	SPY Black Series Bi-Metal Recip, 6 TPI, 12" - 3 Pack	2
200307	SPY Black Series Bi-Metal Recip, 10/14 TPI, 12" - 3 Pack	2
200308	SPY Black Series Bi-Metal Recip, 14pc recip Kit	2
200319	Mach-Blue 6" 10/14 TPI Recip Blade - 2 Pack	2
200320	Mach-Blue 6" 18TPI Recip Blade 2 Pack	2
200321	Mach-Blue 9-IN 6TPI Recip Blade - 2 Pack	2
200322	Mach-Blue 9-IN 10/14TPI Recip Blade - 2 Pack	2
200323	Mach-Blue 12-IN 6TPI Recip Blade - 2 Pack	2
200324	Mach-Blue 12-IN 10/14TPI Recip Blade - 2 Pack	2

Item#	Description	QTY
300037	SPY Jig Saw, 2-Side & Skeleton Wood Cutting CRV, 8pc	2
300002	DOUBLE SIDED JIGSAW 4.5" - 2PC WOOD	2
300004	DOUBLE SIDED JIGSAW 4" - 2PC MULTI SURFACE	2
300009	DOUBLE SIDED JIGSAW - 2PC COMBO SET	2
300012	SKELETON JIGSAW 4" - 2PC NEUTRAL/CLEAN	2
300020	SKELETON JIGSAW - 2PC COMBO SET	2
300022	SKELETON JIGSAW 4" - 2PC HARD & SOFT WOOD	2
300061	5pc Jigsaw Wood Set	2
300062	5pc Jigsaw Multi Set	2
300063	5pc Jigsaw Metal Set	2
300064	10pc Jigsaw, Wood/Metal Set	2
300065	12pc Jigsaw Dbl, Skeleton, Wood, Metal Set	2
300088	SPY Jig Saw Set on card, Laminate Cutting, BIM, 5pc	2
300089	Spy Jig Saw Set on Card, Multi-Material Cutting, CRV, 5pc	2
300090	Spy Jig Saw Set with Case, Multi-Material Cutting, 10pc	2
300091	Spy Jig Saw Set with Case, Multi-Material Cutting, 20pc	2
300097	Spy Jig Saw, Set with Case, Wood Cutting CRV, 8pc	2
300098	Spy Jig Saw, Wood & Metal Cutting BIM, 6/10 TPI, 3pc	2
300099	Spy Jig Saw, 2-Side Wood Cutting CRV, 8/11 TPI, 2pc	2
300100	Spy Jig Saw, 2-Side Wood Cutting CRV, 10/18 TPI, 2pc	2
300101	Spy Jig Saw, Skeleton Wood Cutting CRV, 10 TPI, 2pc	2
300102	Spy Jig Saw, Skeleton Wood Cutting CRV, 17 TPI, 2pc	2

LINEAR EDGE



**TUNGSTEN CARBIDE TIPPED (TCT)
RAPID CORE EJECT™ HOLE SAWS**

CARBIDE TIPPED

Extreme Material Versatility and Faster Cuts

- Up to **10x more cuts** than bi-metal hole saws.
- Up to **5x faster than** standard hole saws.
- Tungsten Carbide Tipped for extended life and clean cuts.
- Cuts wood, concrete block, brick, fiber cement board, PVC and more, with a Mohs hardness of less than 6†.
- Up to 2-3/8" Depth of Cut.
- Utilizes Rapid Core Eject™ Arbor System – rapidly eject the core, quickly change diameter, cut at an angle and enlarge existing holes.
- For use in standard rotary drills, **not for use in hammer drill mode.**

UP TO
10x
MORE

UP TO
5x
FASTER

All Spyder® TCT Hole Saws are compatible with Rapid Core Eject™ Arbor System



Remove the Core with a Push of the Button!



Tungsten Carbide Tipped for Extended Life and Clean Cuts.

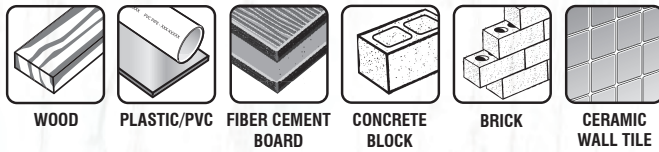

WOOD

PLASTIC/PVC

FIBER CEMENT BOARD

CONCRETE BLOCK

BRICK

CERAMIC WALL TILE

† These hole saws are not recommended for harder, abrasive materials including floor tile, porcelains and poured concrete, which may have a Mohs hardness of 6 or greater.

ELECTRICAL TUNGSTEN CARBIDE TIPPED (TCT) HOLE SAWS

600984

Item#	Description	QTY
600970	174a TCT SM HS Shelf	1
600971	174a TCT MED HS Shelf	2
600972	174a TCT LG DIA HS Shelf	1
600002CF	7/8in RCE TCT Hole Saw	2
600005CF	3/4in RCE TCT Hole Saw	2
600009CF	1-1/8in RCE TCT Hole Saw	2
600013CF	1-3/8in RCE TCT Hole Saw	2
600019CF	1-3/4in RCE TCT Hole Saw	2
600022CF	2in RCE TCT Hole Saw	2
600028CF	2-1/2in RCE TCT Hole Saw	2
600032CF	2-3/4in RCE TCT Hole Saw	2
600034CF	3in RCE TCT Hole Saw	2
600039CF	3-5/8in RCE TCT Hole Saw	2
600041CF	3-3/4in RCE TCT Hole Saw	2
600042CF	4in RCE TCT Hole Saw	2
600044CF	4-1/4in RCE TCT Hole Saw	2
600046CF	4-1/2in RCE TCT Hole Saw	2
600051CF	6-1/4in RCE TCT Hole Saw	2
600117CF	6-3/8in RCE TCT Hole Saw	2



Fixture view for example use only

To use hole saw shelves on slotwall, use the Slotwall Grid Mount (1x), 600973

HOLE SAWS

PRO POWERED TOOLS

PLUMBING TUNGSTEN CARBIDE TIPPED (TCT) HOLE SAWS

CARBIDE TIPPED

600985

Item#	Description	QTY
600970	174a TCT SM HS Shelf	2
600971	174a TCT MED HS Shelf	1
600972	174a TCT LG DIA HS Shelf	2
600005CF	3/4in RCE TCT Hole Saw	2
600002CF	7/8in RCE TCT Hole Saw	2
600007CF	1in RCE TCT Hole Saw	2
600009CF	1-1/8in RCE TCT Hole Saw	2
600011CF	1-1/4in RCE TCT Hole Saw	2
600013CF	1-3/8in RCE TCT Hole Saw	2
600019CF	1-3/4in RCE TCT Hole Saw	2
600021CF	1-7/8in RCE TCT Hole Saw	2
600022CF	2in RCE TCT Hole Saw	2
600027CF	2-3/8in RCE TCT Hole Saw	2
600028CF	2-1/2in RCE TCT Hole Saw	2
600034CF	3in RCE TCT Hole Saw	2
600038CF	3-1/2in RCE TCT Hole Saw	2
600039CF	3-5/8in RCE TCT Hole Saw	2
600042CF	4in RCE TCT Hole Saw	2
600043CF	4-1/8in RCE TCT Hole Saw	2
600046CF	4-1/2in RCE TCT Hole Saw	2
600055CF	4-5/8in RCE TCT Hole Saw	2
600052CF	6in RCE TCT Hole Saw	2
600051CF	6-1/4in RCE TCT Hole Saw	2
600054CF	6-5/8in RCE TCT Hole Saw	2



Fixture view for example use only

HOLE SAWS

To use hole saw shelves on slotwall, use the Slotwall Grid Mount (1x), 600973



COMPLETE ASSORTMENT TUNGSTEN CARBIDE TIPPED (TCT) HOLE SAWS

600983

HOLE SAWS

Item#	Description	QTY
600970	174a TCT SM HS Shelf	2
600971	174a TCT MED HS Shelf	3
600972	174a TCT LG DIA HS Shelf	3
600005CF	3/4in RCE TCT Hole Saw	2
600002CF	7/8in RCE TCT Hole Saw	2
600007CF	1in RCE TCT Hole Saw	2
600009CF	1-1/8in RCE TCT Hole Saw	2
600011CF	1-1/4in RCE TCT Hole Saw	2
600013CF	1-3/8in RCE TCT Hole Saw	2
600015CF	1-1/2in RCE TCT Hole Saw	2
600017CF	1-5/8in RCE TCT Hole Saw	2
600019CF	1-3/4in RCE TCT Hole Saw	2
600021CF	1-7/8in RCE TCT Hole Saw	2
600022CF	2in RCE TCT Hole Saw	2
600024CF	2-1/8in RCE TCT Hole Saw	2
600025CF	2-1/4in RCE TCT Hole Saw	2
600027CF	2-3/8in RCE TCT Hole Saw	2
600028CF	2-1/2in RCE TCT Hole Saw	2
600029CF	2-9/16in RCE TCT Hole Saw	2
600030CF	2-5/8in RCE TCT Hole Saw	2
600032CF	2-3/4in RCE TCT Hole Saw	2
600034CF	3in RCE TCT Hole Saw	2
600036CF	3-1/4in RCE TCT Hole Saw	2
600038CF	3-1/2in RCE TCT Hole Saw	2
600039CF	3-5/8in RCE TCT Hole Saw	2
600041CF	3-3/4in RCE TCT Hole Saw	2
600042CF	4in RCE TCT Hole Saw	2
600043CF	4-1/8in RCE TCT Hole Saw	2
600044CF	4-1/4in RCE TCT Hole Saw	2
600046CF	4-1/2in RCE TCT Hole Saw	2
600055CF	4-5/8in RCE TCT Hole Saw	2
600047CF	4-3/4in RCE TCT Hole Saw	2
600048CF	5in RCE TCT Hole Saw	2
600050CF	5-1/2in RCE TCT Hole Saw	2
600116CF	5-3/4in RCE TCT Hole Saw	2
600052CF	6in RCE TCT Hole Saw	2
600051CF	6-1/4in RCE TCT Hole Saw	2
600117CF	6-3/8in RCE TCT Hole Saw	2
600054CF	6-5/8in RCE TCT Hole Saw	2



Fixture view for example use only

To use hole saw shelves on slotwall, use the Slotwall Grid Mount (2x), 600973

TARANTULA™ RAPID CORE EJECT™ HOLE SAWS

Cut the Toughest Materials

- Up to **50x more cuts** than bi-metal hole saws.
- Up to **10x faster** than standard hole saws.
- Carbide tipped for extended life in tough materials.
- Cuts nail-embedded wood, steel, stainless steel, plastics, non-ferrous metals and fiber cement board.
- *Not recommended for harder, abrasive materials.*
- Up to 2-3/8" Depth of Cut.
- Utilizes Rapid Core Eject™ Arbor System - rapidly eject the core, quickly change diameter, cut at an angle and enlarge existing holes.
- For use in standard rotary drills, **not for use in hammer drill mode.**

UP TO
50x
MORE

UP TO
10x
FASTER



Remove the Core with a Push of the Button!

All Spyder® TARANTULA™ Hole Saws are compatible with Rapid Core Eject™ Arbor System

Carbide Tipped for Extended Life in Tough Materials.

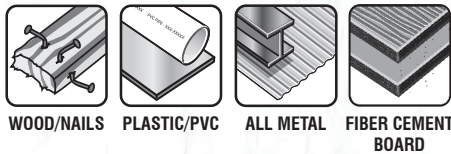

HOLE SAWS



ELECTRICAL TARANTULA™ HOLE SAWS

600987

Item#	Description	QTY
600970	174a TCT SM HS Shelf	1
600971	174a TCT MED HS Shelf	1
600972	174a TCT LG DIA HS Shelf	1
600895CF	7/8in Tarantula RCE Hole Saw	2
600896CF	1in Tarantula RCE Hole Saw	2
600898CF	1-1/8in Tarantula RCE Hole Saw	2
600900CF	1-3/8in Tarantula RCE Hole Saw	2
600903CF	1-3/4in Tarantula RCE Hole Saw	2
600927CF	1-7/8in Tarantula RCE Hole Saw	2
600905CF	2in Tarantula RCE Hole Saw	2
600909CF	2-1/2in Tarantula RCE Hole Saw	2
600912CF	2-3/4in Tarantula RCE Hole Saw	2
600913CF	3in Tarantula RCE Hole Saw	2
600915CF	4in Tarantula RCE Hole Saw	2
600916CF	4-1/4in Tarantula RCE Hole Saw	2
600917CF	4-1/2in Tarantula RCE Hole Saw	2

To use hole saw shelves on slotwall, use the Slotwall Grid Mount (1x), 600973



Fixture view for example use only

PLUMBING TARANTULA™ HOLE SAWS

600988

Item#	Description	QTY
600970	174a TCT SM HS Shelf	2
600971	174a TCT MED HS Shelf	1
600972	174a TCT LG DIA HS Shelf	1
600895CF	7/8in Tarantula RCE Hole Saw	2
600896CF	1in Tarantula RCE Hole Saw	2
600898CF	1-1/8in Tarantula RCE Hole Saw	2
600899CF	1-1/4in Tarantula RCE Hole Saw	2
600900CF	1-3/8in Tarantula RCE Hole Saw	2
600903CF	1-3/4in Tarantula RCE Hole Saw	2
600904CF	1-7/8in Tarantula RCE Hole Saw	2
600905CF	2in Tarantula RCE Hole Saw	2
600908CF	2-3/8in Tarantula RCE Hole Saw	2
600909CF	2-1/2in Tarantula RCE Hole Saw	2
600913CF	3in Tarantula RCE Hole Saw	2
600914CF	3-1/2in Tarantula RCE Hole Saw	2
600927CF	3-5/8in Tarantula RCE Hole Saw	2
600915CF	4in Tarantula RCE Hole Saw	2
600916CF	4-1/4in Tarantula RCE Hole Saw	2
600917CF	4-1/2in Tarantula RCE Hole Saw	2

To use hole saw shelves on slotwall, use the Slotwall Grid Mount (1x), 600973



Fixture view for example use only

COMPLETE ASSORTMENT TARANTULA™ HOLE SAWS

600986

Item#	Description	QTY
600970	174a TCT SM HS Shelf	2
600971	174a TCT MED HS Shelf	2
600972	174a TCT LG DIA HS Shelf	2
600895CF	7/8in Tarantula RCE Hole Saw	2
600896CF	1in Tarantula RCE Hole Saw	2
600897CF	1-1/16in Tarantula RCE Hole Saw	2
600898CF	1-1/8in Tarantula RCE Hole Saw	2
600899CF	1-1/4in Tarantula RCE Hole Saw	2
600900CF	1-3/8in Tarantula RCE Hole Saw	2
600901CF	1-1/2in Tarantula RCE Hole Saw	2
600902CF	1-5/8in Tarantula RCE Hole Saw	2
600903CF	1-3/4in Tarantula RCE Hole Saw	2
600904CF	1-7/8in Tarantula RCE Hole Saw	2
600905CF	2in Tarantula RCE Hole Saw	2
600906CF	2-1/8in Tarantula RCE Hole Saw	2
600907CF	2-1/4in Tarantula RCE Hole Saw	2
600908CF	2-3/8in Tarantula RCE Hole Saw	2
600909CF	2-1/2in Tarantula RCE Hole Saw	2
600910CF	2-9/16in Tarantula RCE Hole Saw	2
600911CF	2-5/8in Tarantula RCE Hole Saw	2
600912CF	2-3/4in Tarantula RCE Hole Saw	2
600913CF	3in Tarantula RCE Hole Saw	2
600914CF	3-1/2in Tarantula RCE Hole Saw	2
600927CF	3-5/8in Tarantula RCE Hole Saw	2
600915CF	4in Tarantula RCE Hole Saw	2
600916CF	4-1/4in Tarantula RCE Hole Saw	2
600917CF	4-1/2in Tarantula RCE Hole Saw	2



Fixture view for example use only

HOLE SAWS

To use hole saw shelves on slotwall, use the Slotwall Grid Mount (1x), 600973



BI-METAL RAPID CORE EJECT™ HOLE SAWS

Tough Bi-Metal Steel for Long Life

- Up to **5x faster** when used with our Rapid Core Eject™ Arbor System.
- Variable tooth pitch guarantees a fast and clean cut through all material thicknesses.
- Creates smooth cuts in steel, stainless steel, aluminum, nail-embedded wood, non-ferrous metal, plastics / PVC and more.
- Up to 1-7/8" Depth of Cut.

UP TO
5x
FASTER

All Spyder® Bi-Metal Hole Saws are compatible with Rapid Core Eject™ Arbor System



Remove the Core with a Push of the Button!

Variable Tooth Pitch Guarantees a Fast and Clean Cut.



WOOD/NAILS

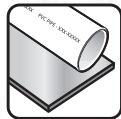

PLASTIC/PVC



STEEL/METAL



NON-FERROUS METAL



ELECTRICAL BI-METAL HOLE SAWS

600981

Item#	Description	QTY
600967	170a BIM SM HS Shelf	1
600968	170a BIM MED HS Shelf	1
600969	170a BIM LG DIA HS Shelf	2
600061CF	3/4in BIM RCE Hole Saw	2
600064CF	7/8in BIM RCE Hole Saw	2
600068CF	1-1/8in BIM RCE Hole Saw	2
600072CF	1-3/8in BIM RCE Hole Saw	2
600078CF	1-3/4in BIM RCE Hole Saw	2
600081CF	2in BIM RCE Hole Saw	2
600087CF	2-1/2in BIM RCE Hole Saw	2
600091CF	2-3/4in BIM RCE Hole Saw	2
600093CF	3in BIM RCE Hole Saw	2
600098CF	3-5/8in BIM RCE Hole Saw	2
600101CF	4in BIM RCE Hole Saw	2
600103CF	4-1/4in BIM RCE Hole Saw	2
600105CF	4-1/2in BIM RCE Hole Saw	2
600109CF	5-1/2in BIM RCE Hole Saw	2
600928CF	6-3/8in BIM RCE Hole Saw	2
600113CF	6-5/8in BIM RCE Hole Saw	2



Fixture view for example use only

To use hole saw shelves on slotwall, use the Slotwall Grid Mount (1x), 600973

PLUMBING BI-METAL HOLE SAWS

600982

Item#	Description	QTY
600967	170a BIM SM HS Shelf	2
600968	170a BIM MED HS Shelf	1
600969	170a BIM LG DIA HS Shelf	2
600061CF	3/4in BIM RCE Hole Saw	2
600064CF	7/8in BIM RCE Hole Saw	2
600066CF	1in BIM RCE Hole Saw	2
600068CF	1-1/8in BIM RCE Hole Saw	2
600070CF	1-1/4in BIM RCE Hole Saw	2
600072CF	1-3/8in BIM RCE Hole Saw	2
600078CF	1-3/4in BIM RCE Hole Saw	2
600080CF	1-7/8in BIM RCE Hole Saw	2
600081CF	2in BIM RCE Hole Saw	2
600086CF	2-3/8in BIM RCE Hole Saw	2
600087CF	2-1/2in BIM RCE Hole Saw	2
600093CF	3in BIM RCE Hole Saw	2
600097CF	3-1/2in BIM RCE Hole Saw	2
600098CF	3-5/8in BIM RCE Hole Saw	2
600101CF	4in BIM RCE Hole Saw	2
600102CF	4-1/8in BIM RCE Hole Saw	2
600105CF	4-1/2in BIM RCE Hole Saw	2
600106CF	4-5/8in BIM RCE Hole Saw	2
600111CF	6in BIM RCE Hole Saw	2
600928CF	6-3/8in BIM RCE Hole Saw	2
600113CF	6-5/8in BIM RCE Hole Saw	2



HOLE SAWS

Fixture view for example use only

To use hole saw shelves on slotwall, use the Slotwall Grid Mount (1x), 600973



COMPLETE ASSORTMENT BI-METAL HOLE SAWS

600980

Item#	Description	QTY
600967	170a BIM SM HS Shelf	2
600968	170a BIM MED HS Shelf	2
600969	170a BIM LG DIA HS Shelf	3
600061CF	3/4in BIM RCE Hole Saw	2
600064CF	7/8in BIM RCE Hole Saw	2
600066CF	1in BIM RCE Hole Saw	2
600068CF	1-1/8in BIM RCE Hole Saw	2
600070CF	1-1/4in BIM RCE Hole Saw	2
600072CF	1-3/8in BIM RCE Hole Saw	2
600074CF	1-1/2in BIM RCE Hole Saw	2
600076CF	1-5/8in BIM RCE Hole Saw	2
600078CF	1-3/4in BIM RCE Hole Saw	2
600080CF	1-7/8in BIM RCE Hole Saw	2
600081CF	2in BIM RCE Hole Saw	2
600083CF	2-1/8in BIM RCE Hole Saw	2
600084CF	2-1/4in BIM RCE Hole Saw	2
600086CF	2-3/8in BIM RCE Hole Saw	2
600087CF	2-1/2in BIM RCE Hole Saw	2
600089CF	2-5/8in BIM RCE Hole Saw	2
600091CF	2-3/4in BIM RCE Hole Saw	2
600093CF	3in BIM RCE Hole Saw	2
600095CF	3-1/4in BIM RCE Hole Saw	2
600097CF	3-1/2in BIM RCE Hole Saw	2
600098CF	3-5/8in BIM RCE Hole Saw	2
600101CF	4in BIM RCE Hole Saw	2
600102CF	4-1/8in BIM RCE Hole Saw	2
600103CF	4-1/4in BIM RCE Hole Saw	2
600105CF	4-1/2in BIM RCE Hole Saw	2
600106CF	4-5/8in BIM RCE Hole Saw	2
600100CF	4-3/4in BIM RCE Hole Saw	2
600107CF	5in BIM RCE Hole Saw	2
600109CF	5-1/2in BIM RCE Hole Saw	2
600110CF	5-3/4in BIM RCE Hole Saw	2
600111CF	6in BIM RCE Hole Saw	2
600928CF	6-3/8in BIM RCE Hole Saw	2
600113CF	6-5/8in BIM RCE Hole Saw	2



Fixture view for example use only

To use hole saw shelves on slotwall, use the Slotwall Grid Mount (2x), 600973

HOLE SAWS

HOLE SAW KITS

Carbide Tipped (TCT), Bi-Metal, and Tarantula Kits

- Speed through tough jobs with Spyder's patented Rapid Core Eject™ Arbor System.
- Completes the job 5x faster than the competition and makes your time more valuable.
- Rugged, hard plastic carry case keeps your tools organized.

Rugged, Hard Plastic Carry Case

Select kits only

Kits, in a carry case, available in multiple configurations:

- TCT Kits include 6, 14 or 18 pieces
- Tarantula Kit includes 9 pieces
- Bi-Metal Kits include 11 or 13 pieces
- Pro Pack includes 14 piece TCT Kit and 13 piece Bi-Metal Kit



All of our hole saw kits utilize our Spyder® Patented Rapid Core Eject™ Arbor System

Remove the Core with a Push of the Button!



HOLE SAWS

HOLE SAW KITS

600976

Item#	Description	QTY
600887	SPY Bi-Metal Hole Saw Kit, 13pc	2
600925	SPY Tarantula Hole Saw Kit, 9pc	2
600938	SPY TCT Hole Saw Kit, 18pc	2
600939	SPY TCT & BIM Hole Saw Kit Pro Pack, 27pc	2
600922	SPY TCT Kit, 6pc	2



TUNGSTEN CARBIDE TIPPED (TCT) DEEP CUT HOLE SAWS

Extreme Material Versatility and Faster Cuts

- Up to **10x more cuts** than bi-metal hole saws.
- Tungsten Carbide Tipped for extended life and clean cuts.
- Cuts wood, concrete block, brick, fiber cement board, PVC and more, with a Mohs hardness of less than 6†.
- Up to 6-1/4" Depth of Cut.
- Deep Cut Hole Saws use Hex11 deep cut arbor and pilot bit. Not compatible with the Rapid Core Eject™ Arbor System.
- For use in standard rotary drills, **not for use in hammer drill mode.**

UP TO
10x
MORE



Tungsten Carbide Tipped for Extended Life and Clean Cuts.

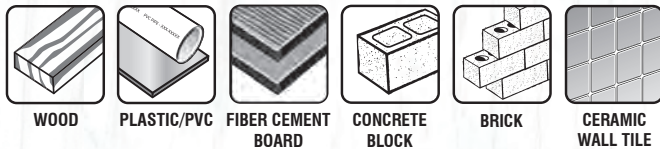

Spyder® Deep Cut Hole Saws are not compatible with our Rapid Core Eject™ system.

† These hole saws are not recommended for harder, abrasive materials including floor tile, porcelains and poured concrete, which may have a Mohs hardness of 6 or greater.

TCT DEEP CUT HOLE SAW

600989

Item#	Description	QTY
900520	REORDER BACKCARDS	5
600825	6.5" Deep Cut TCT, Hole Saw, 1-1/4"	1
600826	6.5" Deep Cut TCT, Hole Saw, 1-3/4"	1
600827	6.5" Deep Cut TCT, Hole Saw, 2"	1
600828	6.5" Deep Cut TCT, Hole Saw, 2-3/8"	1
600829	6.5" Deep Cut TCT, Hole Saw, 2-9/16"	1
600830	6.5" Deep Cut TCT, Hole Saw, 3"	1
600831	6.5" Deep Cut TCT, Hole Saw, 3-3/8"	1
600832	6.5" Deep Cut TCT, Hole Saw, 3-5/8"	1
600833	6.5" Deep Cut TCT, Hole Saw, 4"	1
600834	6.5" Deep Cut TCT, Hole Saw, 4-1/8"	1
600835	6.5" Deep Cut TCT, Hole Saw, 4-3/8"	1
600836	6.5" Deep Cut TCT, Hole Saw, 4-3/4"	1
600837	6.5" Deep Cut TCT, Hole Saw, 5-1/4"	1
600838	6.5" Deep Cut TCT, Hole Saw, 6"	1
600839	6.5" Deep Cut HSS Arbor	6
600840	6.5" Deep Cut TCT Arbor	6
600841	6.5" Deep Cut HSS Replacement Bit	6
600842	6.5" Deep Cut TCT Replacement Bit	6

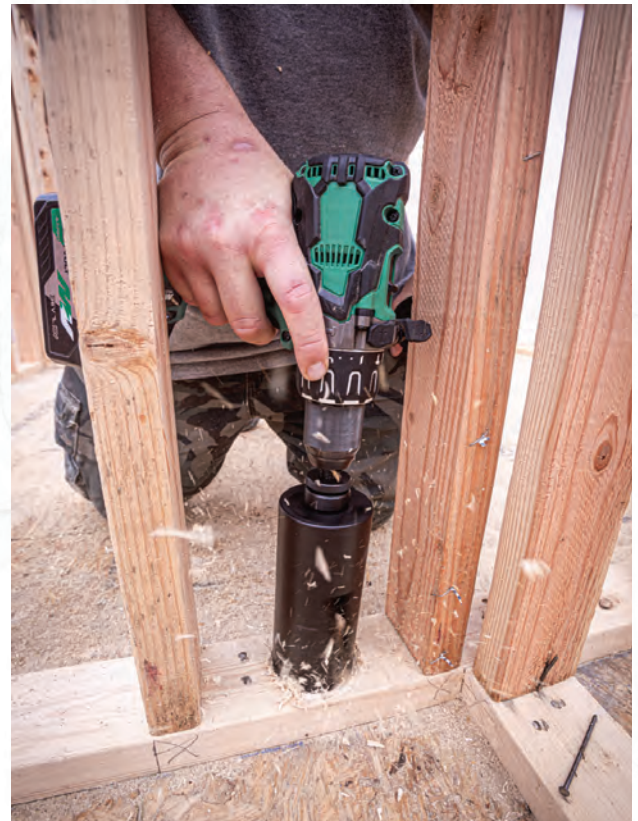

PRO POWERED TOOLS

RAPID CORE EJECT™ ARBOR SYSTEM

The Most Efficient Hole Saw System Ever Made!

- Ejects core with a push of a button, screwdriver not required.
- Up to **5x faster** than the competition.
- Use with Spyder TCT, Bi-Metal and Tarantula™ Hole Saws or with any threaded hole saw.
- Hex8 Adaptors are for hole saw sizes 1-1/8" or smaller
- Hex10 Adaptors are for hole saw sizes 1-1/4" and larger
- Pilot Bits available with either Tungsten Carbide Tipped (TCT) or High Speed Steel (HSS).

**UP TO
5x
FASTER**

Ejects Cores Up to 5x Faster than the Competition, with a Push of a Button, Screwdriver not Required.



Remove the Core with a Push of the Button!

EJECT CORES WITH A PUSH OF A BUTTON



CUT AT AN ANGLE AND ENLARGE EXISTING HOLES



HOLE SAW PILOT & ARBOR RACK

600978

Item#	Description	QTY
900722	Pilot Arbor Display	1
900520	REORDER BACKCARDS	13
600634P	SPY RCE Arbor & Pilot Bit HSS HEX 10	6
600635P	SPY RCE Arbor & Pilot Bit TCT DRILL HEX 10	6
600645P	SPY Pilot Bit HSS HEX 10	6
600646P	SPY Pilot Bit TCT HEX 10	6
600637P	SPY RCE Arbor & Pilot Bit HSS DRILL HEX 8	2
600638P	SPY RCE Arbor & Pilot Bit TCT DRILL HEX 8	2
600648P	SPY Pilot Bit HSS HEX 8	2
600649P	SPY Pilot Bit TCT HEX 8	2
600868P	SPY Arbor Adapter, Hex 8	2
600869P	SPY Arbor Adapter, Hex 10	2
600951	SPY Hole Saw Extension, Hex8 and Hex 10, 6"	3
600952	SPY Hole Saw Extension, Hex8 and Hex 10, 12"	3

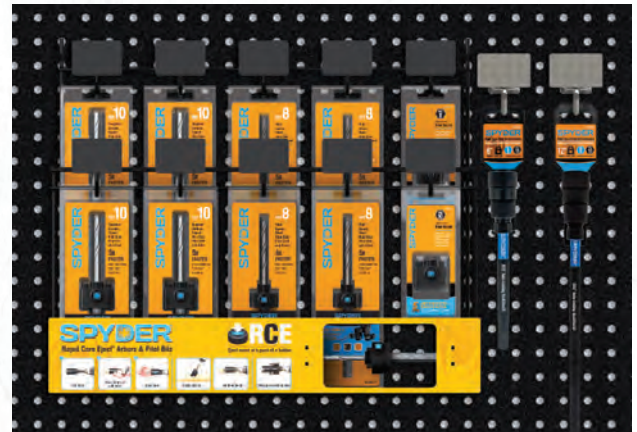

HOLE SAWS

HOLE SAW BIT EXTENSIONS

600975

Item#	Description	QTY
900520	REORDER BACKCARDS	3
600951	SPY Hole Saw Extension, Hex8 and Hex10, 6"	3
600952	SPY Hole Saw Extension, Hex8 and Hex10, 12"	3

- Hex8 / Hex10 6" and 12" Auto-Locking Extensions make drill and extension changes easy.
- Hole Saw bit extensions fits both Hex 8 and Hex 10 Pilot Bits.

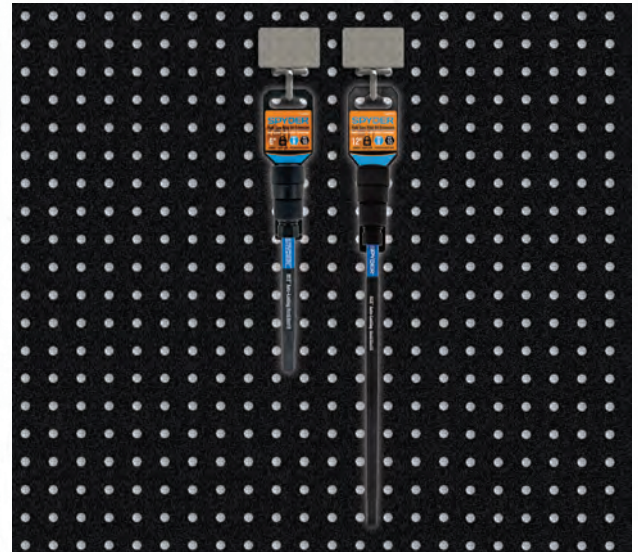

HOLE SAWS

STREAMLINED HOLE SAW BIT EXTENSIONS

600977

Item#	Description	QTY
900520	REORDER BACKCARDS	4
600843	SPY RCE Hex 10-12" Bit Extender	2
600844	SPY RCE Hex 8-12" Bit Extender	2
600845	SPY RCE Hex 10-24" Bit Extender	2

- Size-specific hole saw extension secure with a set screw for confident attachment.

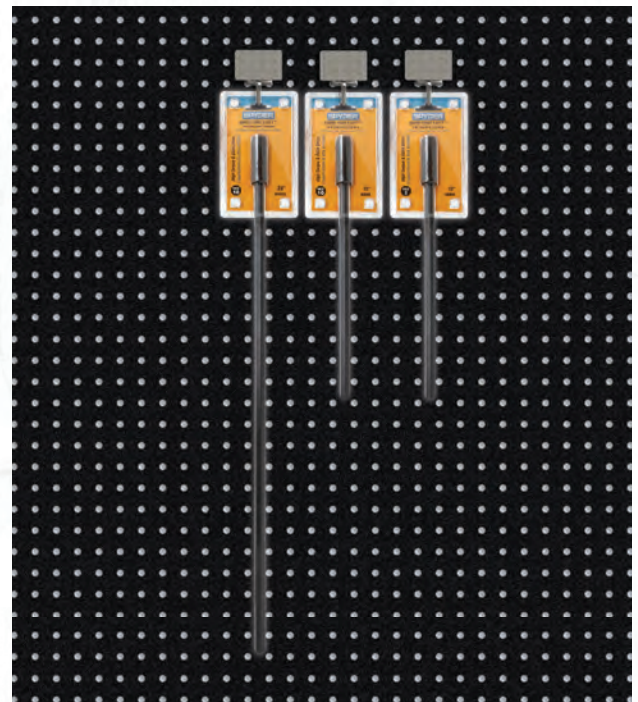

PRO POWERED TOOLS

COMPLETE HOLE SAW ASSORTMENT

600990

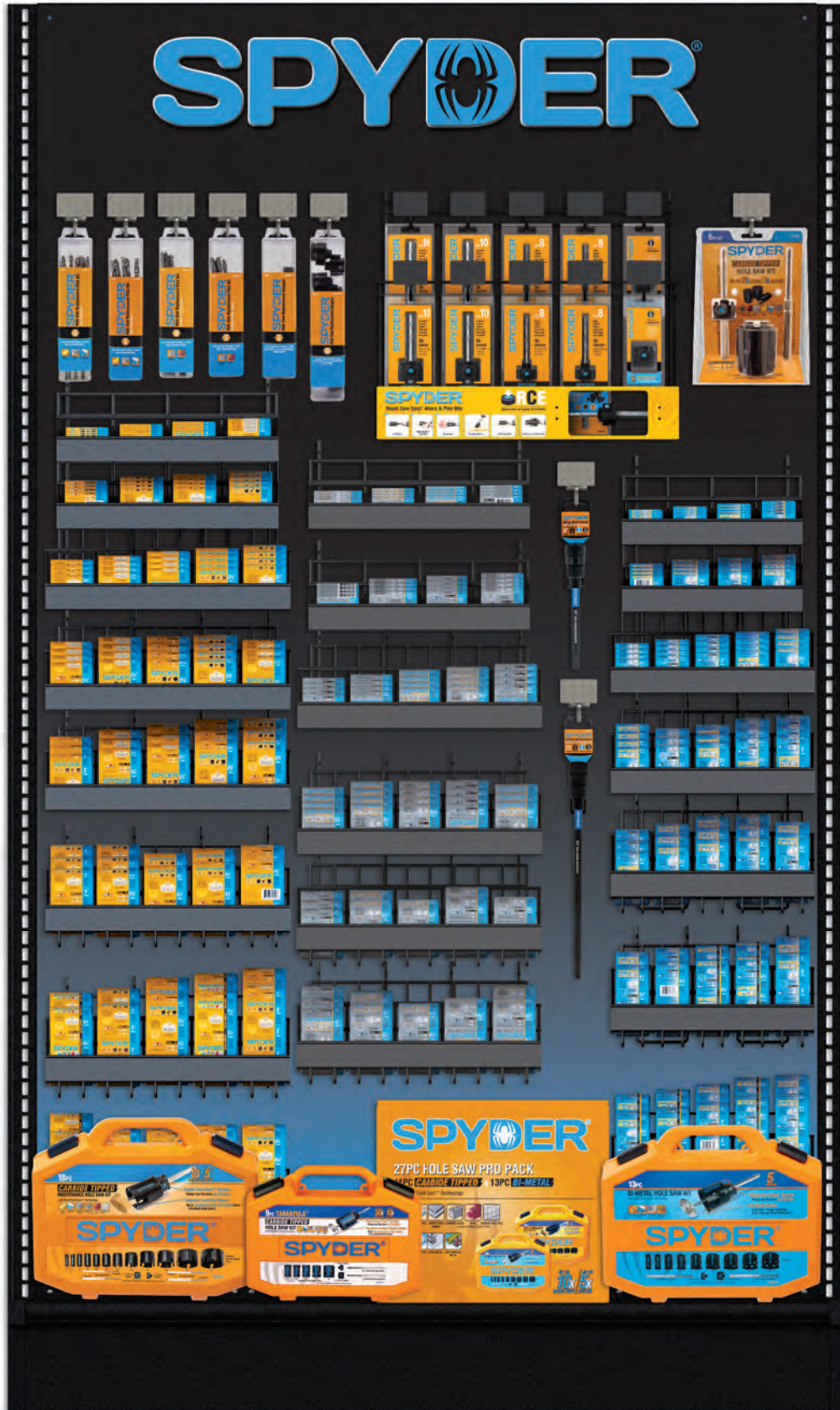

HOLE SAWS

COMPLETE HOLE SAW ASSORTMENT (CONTINUED)

600990

Item#	Description	QTY
600970	174a TCT SM HS Shelf	4
600971	174a TCT MED HS Shelf	5
600972	174a TCT LG DIA HS Shelf	5
600967	170a BIM SM DIA HS Shelf	2
600968	170a BIM MED HS Shelf	2
600969	170a BIM LG DIA HS Shelf	3
900722	Pilot Arbor Display	1
900760	4ft Spyder Gondola Graphic Backpanel	1
900712	4in METAL WIRE SCAN HOOKS .225IN DIA	10
900520	REORDER BACKCARDS	10
600887	SPY Bi-Metal Hole Saw Kit, 13pc	2
600925	SPY Tarantula Hole Saw Kit, 9pc	2
600938	SPY TCT Hole Saw Kit, 18pc	2
600939	SPY TCT & BIM Hole Saw Kit Pro Pack, 27pc	2
600922	SPY TCT Kit, 6pc	2
600634P	SPY RCE ARBR CMPL HSS DRILL HEX10	12
600635P	SPY RCE ARBR CMPL TCT DRILL HEX10	12
600645P	SPYDER PILOT BIT HSS HEX 10	6
600646P	SPYDER PILOT BIT TCT HEX 10	6
600637P	SPY RCE ARBR CMPL HSS DRILL HEX8	6
600638P	SPY RCE ARBR CMPL TCT DRILL HEX8	6
600648P	SPYDER PILOT BIT HSS HEX 8	6
600649P	SPYDER PILOT BIT TCT HEX 8	6
600868P	Arbor Adapter, Hex 8	2
600869P	Arbor Adapter, Hex 10	2
600649-10	Pilotdrill TCT - Hex 8 - 10-CT	2
600648-10	Pilotdrill HSS - Hex 8 - 10-CT	2
600646-10	Pilotdrill TCT - Hex 10 - 10-CT	2
600645-10	Pilotdrill HSS - Hex 10 - 10-CT	2
600869-10	Arbor Adapter, Hex 10 - 10-CT	2
600868-10	Arbor Adapter, Hex 8 - 10-CT	2
600002CF	3/4in RCE TCT Hole Saw	2
600005CF	7/8in RCE TCT Hole Saw	2
600007CF	1in RCE TCT Hole Saw	2
600009CF	1-1/8in RCE TCT Hole Saw	2
600011CF	1-1/4in RCE TCT Hole Saw	2
600013CF	1-3/8in RCE TCT Hole Saw	2
600015CF	1-1/2in RCE TCT Hole Saw	2
600017CF	1-5/8in RCE TCT Hole Saw	2
600019CF	1-3/4in RCE TCT Hole Saw	2
600021CF	1-7/8in RCE TCT Hole Saw	2
600022CF	2in RCE TCT Hole Saw	2

Item#	Description	QTY
600024CF	2-1/8in RCE TCT Hole Saw	2
600025CF	2-1/4in RCE TCT Hole Saw	2
600027CF	2-3/8in RCE TCT Hole Saw	2
600028CF	2-1/2in RCE TCT Hole Saw	2
600029CF	2-9/16in RCE TCT Hole Saw	2
600030CF	2-5/8in RCE TCT Hole Saw	2
600032CF	2-3/4in RCE TCT Hole Saw	2
600034CF	3in RCE TCT Hole Saw	2
600036CF	3-1/4in RCE TCT Hole Saw	2
600038CF	3-1/2in RCE TCT Hole Saw	2
600039CF	3-5/8in RCE TCT Hole Saw	2
600041CF	3-3/4in RCE TCT Hole Saw	2
600042CF	4in RCE TCT Hole Saw	2
600043CF	4-1/8in RCE TCT Hole Saw	2
600044CF	4-1/4in RCE TCT Hole Saw	2
600046CF	4-1/2in RCE TCT Hole Saw	2
600055CF	4-5/8in RCE TCT Hole Saw	2
600047CF	4-3/4in RCE TCT Hole Saw	2
600048CF	5in RCE TCT Hole Saw	2
600050CF	5-1/2in RCE TCT Hole Saw	2
600116CF	5-3/4in RCE TCT Hole Saw	2
600052CF	6in RCE TCT Hole Saw	2
600051CF	6-1/4in RCE TCT Hole Saw	2
600117CF	6-3/8in RCE TCT Hole Saw	2
600054CF	6-5/8in RCE TCT Hole Saw	2
600895CF	7/8in Tarantula RCE Hole Saw	2
600896CF	1in Tarantula RCE Hole Saw	2
600897CF	1-1/16in Tarantula RCE Hole Saw	2
600898CF	1-1/8in Tarantula RCE Hole Saw	2
600899CF	1-1/4in Tarantula RCE Hole Saw	2
600900CF	1-3/8in Tarantula RCE Hole Saw	2
600901CF	1-1/2in Tarantula RCE Hole Saw	2
600902CF	1-5/8in Tarantula RCE Hole Saw	2
600903CF	1-3/4in Tarantula RCE Hole Saw	2
600904CF	1-7/8in Tarantula RCE Hole Saw	2
600905CF	2in Tarantula RCE Hole Saw	2
600906CF	2-1/8in Tarantula RCE Hole Saw	2
600907CF	2-1/4in Tarantula RCE Hole Saw	2
600908CF	2-3/8in Tarantula RCE Hole Saw	2
600909CF	2-1/2in Tarantula RCE Hole Saw	2
600910CF	2-9/16in Tarantula RCE Hole Saw	2
600911CF	2-5/8in Tarantula RCE Hole Saw	2

PRO POWERED TOOLS

COMPLETE HOLE SAW ASSORTMENT (CONTINUED)

600990

Item#	Description	QTY
600912CF	2-3/4in Tarantula RCE Hole Saw	2
600913CF	3in Tarantula RCE Hole Saw	2
600914CF	3-1/2in Tarantula RCE Hole Saw	2
600927CF	3-5/8in Tarantula RCE Hole Saw	2
600915CF	4in Tarantula RCE Hole Saw	2
600916CF	4-1/4in Tarantula RCE Hole Saw	2
600917CF	4-1/2in Tarantula RCE Hole Saw	2
600061CF	3/4in BIM RCE Hole Saw	2
600064CF	7/8in BIM RCE Hole Saw	2
600066CF	1in BIM RCE Hole Saw	2
600068CF	1-1/8in BIM RCE Hole Saw	2
600070CF	1-1/4in BIM RCE Hole Saw	2
600072CF	1-3/8in BIM RCE Hole Saw	2
600074CF	1-1/2in BIM RCE Hole Saw	2
600076CF	1-5/8in BIM RCE Hole Saw	2
600078CF	1-3/4in BIM RCE Hole Saw	2
600080CF	1-7/8in BIM RCE Hole Saw	2
600081CF	2in BIM RCE Hole Saw	2
600083CF	2-1/8in BIM RCE Hole Saw	2
600084CF	2-1/4in BIM RCE Hole Saw	2
600086CF	2-3/8in BIM RCE Hole Saw	2
600087CF	2-1/2in BIM RCE Hole Saw	2
600089CF	2-5/8in BIM RCE Hole Saw	2
600091CF	2-3/4in BIM RCE Hole Saw	2
600093CF	3in BIM RCE Hole Saw	2
600095CF	3-1/4in BIM RCE Hole Saw	2
600097CF	3-1/2in BIM RCE Hole Saw	2
600098CF	3-5/8in BIM RCE Hole Saw	2
600101CF	4in BIM RCE Hole Saw	2
600102CF	4-1/8in BIM RCE Hole Saw	2
600103CF	4-1/4in BIM RCE Hole Saw	2
600105CF	4-1/2in BIM RCE Hole Saw	2
600106CF	4-5/8in BIM RCE Hole Saw	2
600100CF	4-3/4in BIM RCE Hole Saw	2
600107CF	5in BIM RCE Hole Saw	2
600109CF	5-1/2in BIM RCE Hole Saw	2
600110CF	5-3/4in BIM RCE Hole Saw	2
600111CF	6in BIM RCE Hole Saw	2
600928CF	6-3/8in BIM RCE Hole Saw	2
600113CF	6-5/8in BIM RCE Hole Saw	2
600951	SPY Hole Saw Extension, Hex8 and Hex10, 6"	3
600952	SPY Hole Saw Extension, Hex8 and Hex10, 12"	3

To use hole saw shelves on slotwall, use the Slotwall Grid Mount (5x), 600973



HOLE SAWS

DIAMOND BITE™ UNIVERSAL CUT-OFF WHEELS

Long-Lasting Diamond Abrasive Powers through Almost any Material

- Lasts up to **100x longer** than conventional cut-off wheels.
- Cuts almost any material - steel, stainless steel, cast iron, rebar, masonry, ceramic tile, composites and more.
- Safer, shatter-resistant steel core won't blow apart like conventional bonded abrasive wheels.
- Lowest cost per cut wheel - spend less time and cost replacing wheels, and more time working.
- Uniform wheel diameter provides a consistent cut.
- Reduced dust and debris during use.

UP TO
100x
LONGER

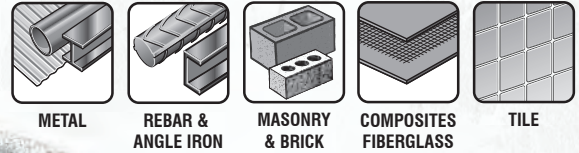

DIAMOND BITE™ CUT-OFF WHEEL

14138

Item#	Description	QTY
900520	REORDER BACKCARDS	10
14003	SPY Diamond Cut-Off Wheel, 3"	3
14004	SPY Diamond Cut-Off Wheel, 4"	3
14001	SPY Diamond Cut-Off Wheel, 4.5"	3
14002	SPY Diamond Cut-Off Wheel, 4.5" - 2pc	3
14005	SPY Diamond Cut-Off Wheel, 5"	3
14007	SPY Diamond Cut-Off Wheel, 7"	3
14007-2	SPY Diamond Cut-Off Wheel, 7" - 2pc	3
14008	SPY Diamond Cut-Off Wheel, 14"	3



DIAMONDBITE™ MASONRY BLADES

Complex Diamond Matrix Continuous Rim, Continuous Turbo Rim & Segmented-Rimmed Blades for Masonry and Tile

- Use the Continuous Rim for ultra clean cutting, Continuous Turbo Rim for fast and clean cutting and Segmented Rim for fast cutting.
- Lasts up to **5x longer** than standard diamond blades.
- Up to **33% faster** and cleaner than standard diamond blades.
- Cuts cooler, quicker, cleaner and longer than standard diamond blades.
- Cut wet or dry for increased versatility.
- Ideal for fast cutting applications including masonry, pavers, concrete and tile.



UP TO
5x
MORE

UP TO
33%
FASTER



DIAMONDBITE™ GRINDING CUP

Complex Diamond Matrix Grinding Cup for Concrete & Masonry Materials

- Blade constructed with a high concentration of premium industrial diamonds bonded in a complex diamond matrix.
- Grinds cooler, quicker, cleaner and longer than standard diamond blades.
- Grind wet or dry for increased versatility.
- Ideal for grinding concrete, pavers, and masonry.
- Use with angle grinder.
- 5/8"-11 arbor.



CONCRETE

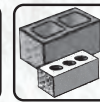

PAVERS & MASONRY



CUT WET OR DRY

DIAMONDBITE™ MASONRY BLADES

14137

Item#	Description	QTY
900520	REORDER BACKCARDS	12
14100	SPY Masonry/Tile Cutting Wheel, Continuous, 4"	2
14101	SPY Masonry/Tile Cutting Wheel, Continuous, 4-1/2"	2
14115	SPY Masonry Cutting Wheel, Cont. Turbo, 4"	2
14116	SPY Masonry Cutting Wheel, Cont. Turbo, 4-1/2"	2
14117	SPY Masonry Cutting Wheel, Cont. Turbo, 7"	2
14118	SPY Masonry Cutting Wheel, Cont. Turbo, 10"	2
14120	SPY Masonry Cutting Wheel, Segmented, 4-1/2"	2
14121	SPY Masonry Cutting Wheel, Segmented, 7"	2
14126	SPY Masonry Cutting Wheel, Modified Seg., 14"	2
14131	SPY Masonry Grinding Wheel, Turbo Double, 4"	2



DIAMOND

DIAMOND BITE™ COMPLETE ASSORTMENT

14136

Item#	Description	QTY
900520	REORDER BACKCARDS	20
14100	SPY Masonry/Tile Cutting Wheel, Continuous, 4"	2
14101	SPY Masonry/Tile Cutting Wheel, Continuous, 4-1/2"	2
14115	SPY Masonry Cutting Wheel, Cont. Turbo, 4"	2
14116	SPY Masonry Cutting Wheel, Cont. Turbo, 4-1/2"	2
14117	SPY Masonry Cutting Wheel, Cont. Turbo, 7"	2
14118	SPY Masonry Cutting Wheel, Cont. Turbo, 10"	2
14120	SPY Masonry Cutting Wheel, Segmented, 4-1/2"	2
14121	SPY Masonry Cutting Wheel, Segmented, 7"	2
14126	SPY Masonry Cutting Wheel, Modified Seg, 14"	2
14131	SPY Masonry Grinding Wheel, Turbo Double, 4"	2
14003	SPY Diamond Cut-Off Wheel, 3"	2
14004	SPY Diamond Cut-Off Wheel, 4"	2
14001	SPY Diamond Cut-Off Wheel, 4.5"	2
14002	SPY Diamond Cut-Off Wheel, 4.5" - 2pc	2
14005	SPY Diamond Cut-Off Wheel, 5"	2
14007	SPY Diamond Cut-Off Wheel, 7"	2
14007-2	SPY Diamond Cut-Off Wheel, 7" - 2pc	2
14008	SPY Diamond Cut-Off Wheel, 14"	2



DIAMOND

32-IN DIAMONDBITE™ ROLLING FLOORSTAND DISPLAY

14139

Item#	Description	QTY
900585	SPYDER ROLLING DISPLAY PEGBOARD 32IN X 60IN BLACK	1
900586	SPYDER ROLLING DISPLAY BASE	1
900576	SPYDER ROLLING DISPLAY BRAND HEADER	1
900712	4in METAL WIRE SCAN HOOKS .225IN DIA THICK	20
900520	REORDER BACKCARDS	20
14100	SPY Masonry/Tile Cutting Wheel, Continuous, 4"	2
14101	SPY Masonry/Tile Cutting Wheel, Continuous, 4-1/2"	2
14115	SPY Masonry Cutting Wheel, Cont. Turbo, 4"	2
14116	SPY Masonry Cutting Wheel, Cont. Turbo, 4-1/2"	2
14117	SPY Masonry Cutting Wheel, Cont. Turbo, 7"	2
14118	SPY Masonry Cutting Wheel, Cont. Turbo, 10"	2
14120	SPY Masonry Cutting Wheel, Segmented, 4-1/2"	2
14121	SPY Masonry Cutting Wheel, Segmented, 7"	2
14126	SPY Masonry Cutting Wheel, Modified Seg, 14"	2
14131	SPY Masonry Grinding Wheel, Turbo Double, 4"	2
14003	SPY Diamond Cut-Off Wheel, 3"	3
14004	SPY Diamond Cut-Off Wheel, 4"	3
14001	SPY Diamond Cut-Off Wheel, 4.5"	3
14002	SPY Diamond Cut-Off Wheel, 4.5" - 2pc	3
14005	SPY Diamond Cut-Off Wheel, 5"	3
14007	SPY Diamond Cut-Off Wheel, 7"	3
14007-2	SPY Diamond Cut-Off Wheel, 7" - 2pc	3
14008	SPY Diamond Cut-Off Wheel, 14"	3



DIAMOND

Single-Sided Display

DIAMOND EDGE HOLE SAWS

Premium Diamond Abrasive Provides Long Tool Life and Clean Cuts

- Up to **20x more holes** than standard diamond hole saws.
- Up to **10x faster** than standard glass and tile hole saws.
- Premium boron-coated, industrial diamond abrasive self-sharpenes for quick cuts and long life in tough tile / masonry materials.
- High-temperature, nickel braze adheres at temperatures up to 1.5x the braze of standard diamond hole saws, for increased diamond abrasive retention.
- Segmented cutting edge enhances cut material evacuation and increases cutting performance.
- Oversized and staggered pry holes enable easy core ejection.
- Heavy-duty, single-piece construction and vacuum-furnace heat-treated, high-alloy steel provides a reliable cut and consistent, round holes.
- Black oxide finish reduces cutting friction and prevents corrosion.
- Can be used wet or dry - water spray or immersion will increase tool life, reduce dust and debris, and create a more quiet cut.
- 1-1/2" depth of cut.
- Made in the USA.



UP TO
20x
MORE

UP TO
10x
FASTER



Not compatible with Rapid Core Eject™ System

Auto-Guide Carbide Tipped Pilot Bit

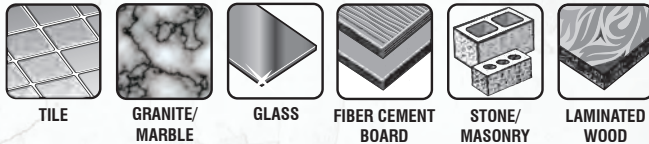

DIAMOND EDGE HOLE SAWS

600979

Item#	Description	QTY
900520	REORDER BACKCARDS	18
600950	SPY 3pc Arborized Diamond Grit Hole Saw Bit Set (1/4, 3/8, 1/2)	3
600846	SPY 3/16" Diamond Arbor Hole Saw Bit	3
600847	SPY 1/4" Diamond Arbor Hole Saw Bit	3
600848	SPY 5/16" Diamond Arbor Hole Saw Bit	3
600849	SPY 3/8" Diamond Arbor Hole Saw Bit	3
600850	SPY 1/2" Diamond Arbor Hole Saw Bit	3
600851	SPY 5/8" Diamond Arbor Hole Saw Bit	3
600852	SPY 3/4" Diamond Arbor Hole Saw Bit	3
600853	SPY 1" Diamond Arbor Hole Saw Bit	3
600854	SPY 1-1/4" Diamond Arbor Hole Saw Bit	3
600855	SPY 1-3/8" Diamond Arbor Hole Saw Bit	3
600857	SPY 1-1/4" Diamond Non-Arbor Hole Saw	3
600858	SPY 1-3/8" Diamond Non-Arbor Hole Saw	3
600859	SPY 1-1/2" Diamond Non-Arbor Hole Saw	3
600860	SPY 2" Diamond Non-Arbor Hole Saw	3
600861	SPY 2-1/2" Diamond Non-Arbor Hole Saw	3
600862	SPY Diamond Hole Saw Arbor	3

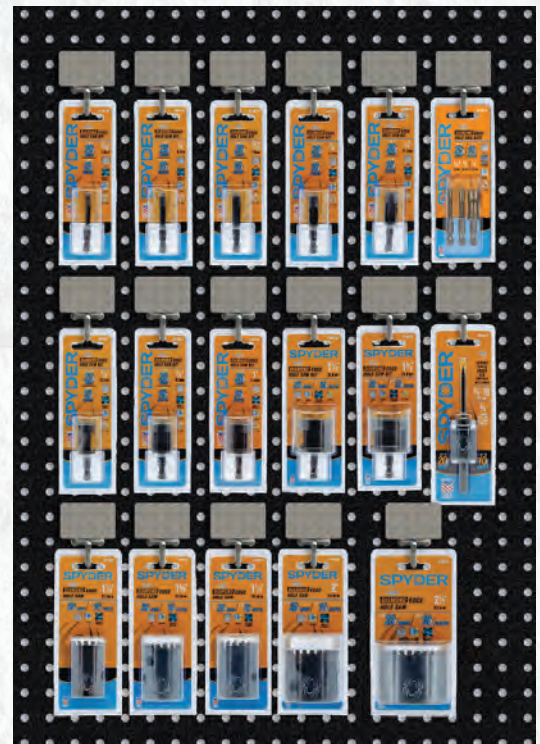

TARANTULA™ CIRCULAR SAW BLADES

NiCo (Nickel Cobalt) Teeth Provide Clean Cuts and Exceptionally Long Life

- Lasts up to **6x longer** than conventional blades.
- Alternating tooth bevel (ATB), alternating tooth bevel with raker (ATB-R) and ultra tough NiCo (nickel cobalt) cutting teeth are sharpened 3x for exceptionally clean cuts.
- Interfused anti-friction coating protects against heat, gumming and corrosion.
- Polymer stabilization vents reduce noise and vibrations.
- Framing / construction blade is up to 3x stronger for reduced blade binding.

ULTRA TOUGH
NiCo
NICKEL COBALT

UP TO
6x
LONGER

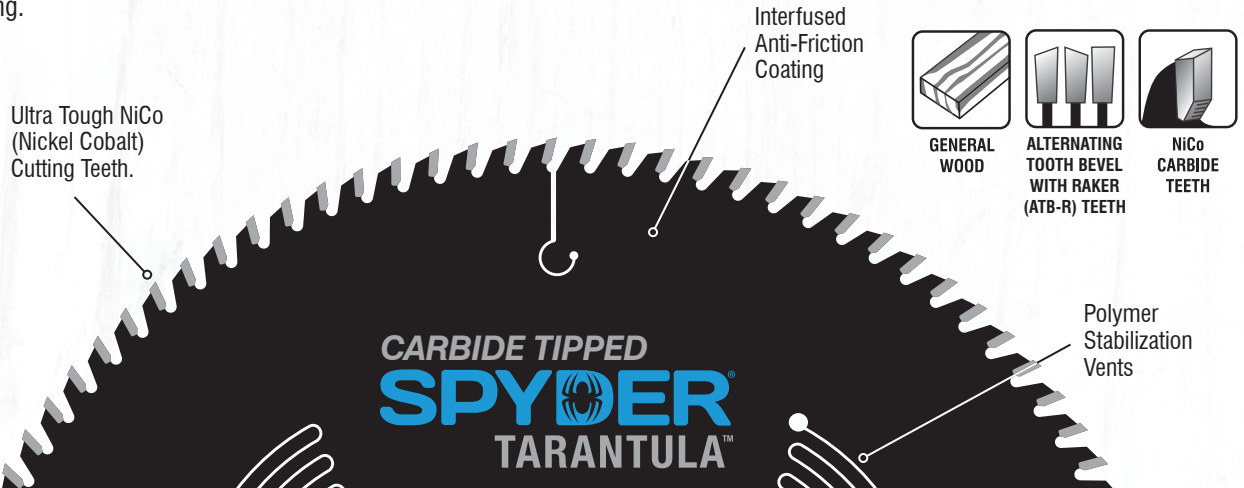

SMALL CIRCULAR SAW BLADES

13085

Item#	Description	QTY
900720	Inline CS Shelf for Circular Saw Blades	16
13510	Inline CS Shelf Graphic Backers (set)	1
13029	SPY 5-1/2in 18T Framing	2
13030	SPY 6-1/2in 18T Framing Blade	2
13004	SPY 6-1/2in 24T Framing Blade	2
13041	SPY 6-1/2in 24T Demolition Blade	2
13025	SPY 6-1/2in 48T - Ultra Fine Finish Blade	2
13028	SPY 7-1/4-in 4T PCD - Fiber Cement Board	2
13001	SPY 7-1/4in 24T Framing Blade	2
13006	SPY 7-1/4in 24T Demolition Blade	2
13007	SPY 7-1/4in 40T Fine Finish Blade	2
13019	SPY 7-1/4in 44T Decking	2
13018	SPY 7-1/4in 60T Ultra Fine Blade	2
13020	SPY 7-1/4in 60T Laminated Wood	2
13001-2	SPY 7-1/4in 24T Framing, 2pk	2
13004-2	SPY 6-1/2in 24T Framing, 2pk	2
13051	SPY 7-1/4in 24T Demo/Framing, 2pk	2
13061	SPY 6-1/2in 24T Demo/Framing, 2pk	2
13017	SPY 7-1/4in 24T Framing Blade 10 Pack	2



Front view



Fixture view

CIRCULAR SAWS

LARGE DIAMETER CIRCULAR SAW BLADES

13084

Item#	Description	QTY
13507	199 CS Small Hanging Bracket	1
13508	199 CS Medium Hanging Bracket	1
13509	199 CS Large Hanging Bracket	1
900712	4in Scan Hooks	15
900520	REORDER BACKCARDS	15
13023	SPY 6in DADO Set	1
13024	SPY 8in DADO Set	1
13031	SPY 8-1/4in 24T Framing - Ring Pack	2
13058	SPY 8-1/4in 40T Framing - Ring Pack	2
13056	SPY 10in 40T General Purpose - Ring Pack	2
13021	SPY 10in 50T Combination Blade - Ring Pack	2
13053	SPY 10in 60T Fine Finish Blade - Ring Pack	2
13055	SPY 10in 80T Ultra Fine Finish Blade - Ring Pack	2
13059	SPY 12in 40T General Purpose Blade - Ring Pack	2
13022	SPY 12in 60T Combination Blade	2
13057	SPY 12in 60T General Purpose Blade - Ring Pack	2
13054	SPY 12in 80T Fine Finish Blade - Ring Pack	2
13027	SPY 12in 100T Ultra Fine Finish Blade - Ring Pack	2

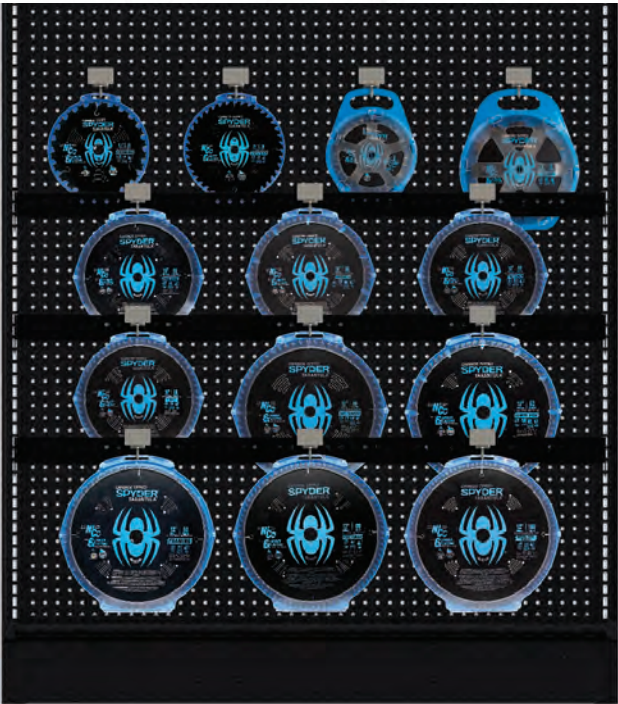

CIRCULAR SAWS

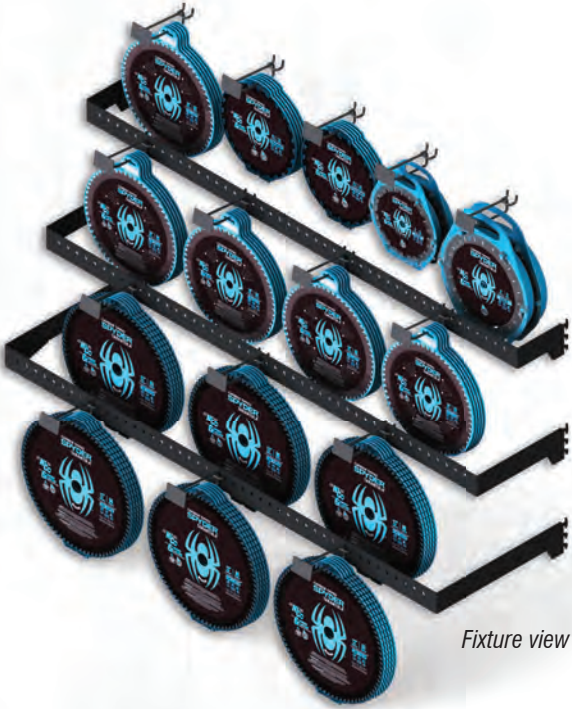

Fixture view

TARANTULA™ DADO CIRCULAR SAW BLADES

Oversized, Ultra Tough NiCo (Nickel Cobalt) Teeth Cut Exceptionally Clean Grooves from 1/4" to 13/16"

- Lasts up to **6x longer** than conventional blades.
- Alternating tooth bevel (ATB) profile on the outer scoring blades and re-sharpenable, oversized ultra tough NiCo (nickel cobalt) cutting teeth are sharpened 3x for exceptionally clean cuts.
- Flat top grind (FTG) chippers cleanly remove material for ultimate cut joints.
- Interfused anti-friction coating protects against heat, gumming and corrosion.
- Cuts grooves from 1/4" to 13/16" in soft and hard woods, plywood and melamine.
- Each set includes 2 blades, 3 chippers, 3 spacers and 8 width alignment shims.

ULTRA TOUGH
NiCo
NICKEL COBALT

UP TO
6x
LONGER

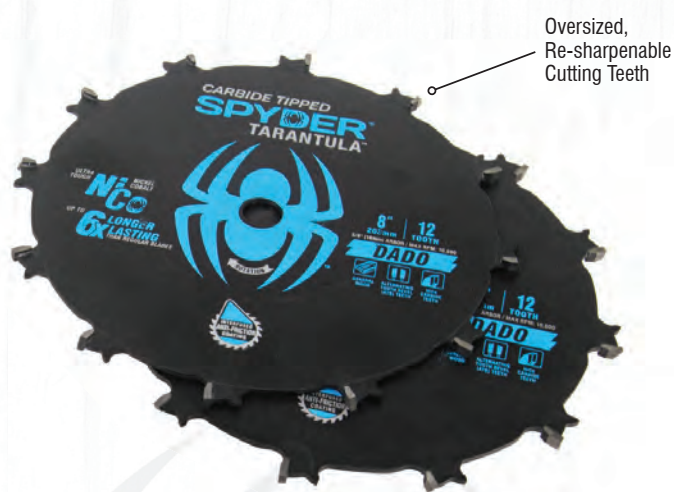
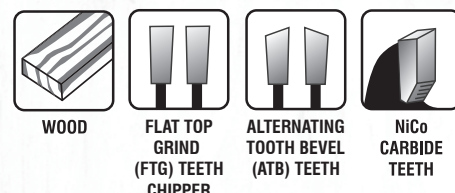

8 Width Alignment Shims
0.1mm [5]
0.2mm [1]
0.3mm [1]
0.5mm [1]



DADO CIRCULAR SAW BLADES

13082

Item#	Description	QTY
900520	REORDER BACKCARDS	2
13023	SPY 6in DADO Set	2
13024	SPY 8in DADO Set	2

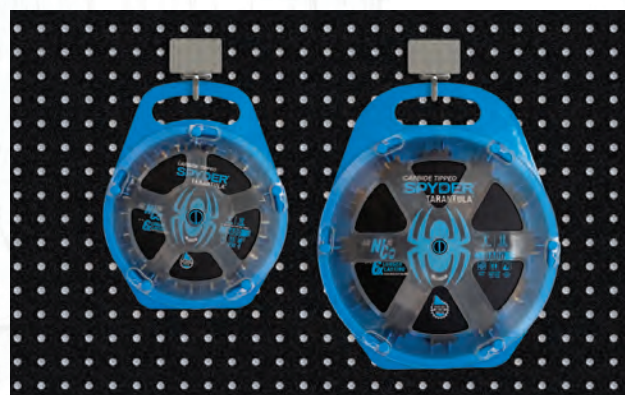

CIRCULAR SAWS

CIRCULAR SAW BLADES COMPLETE ASSORTMENT

13083

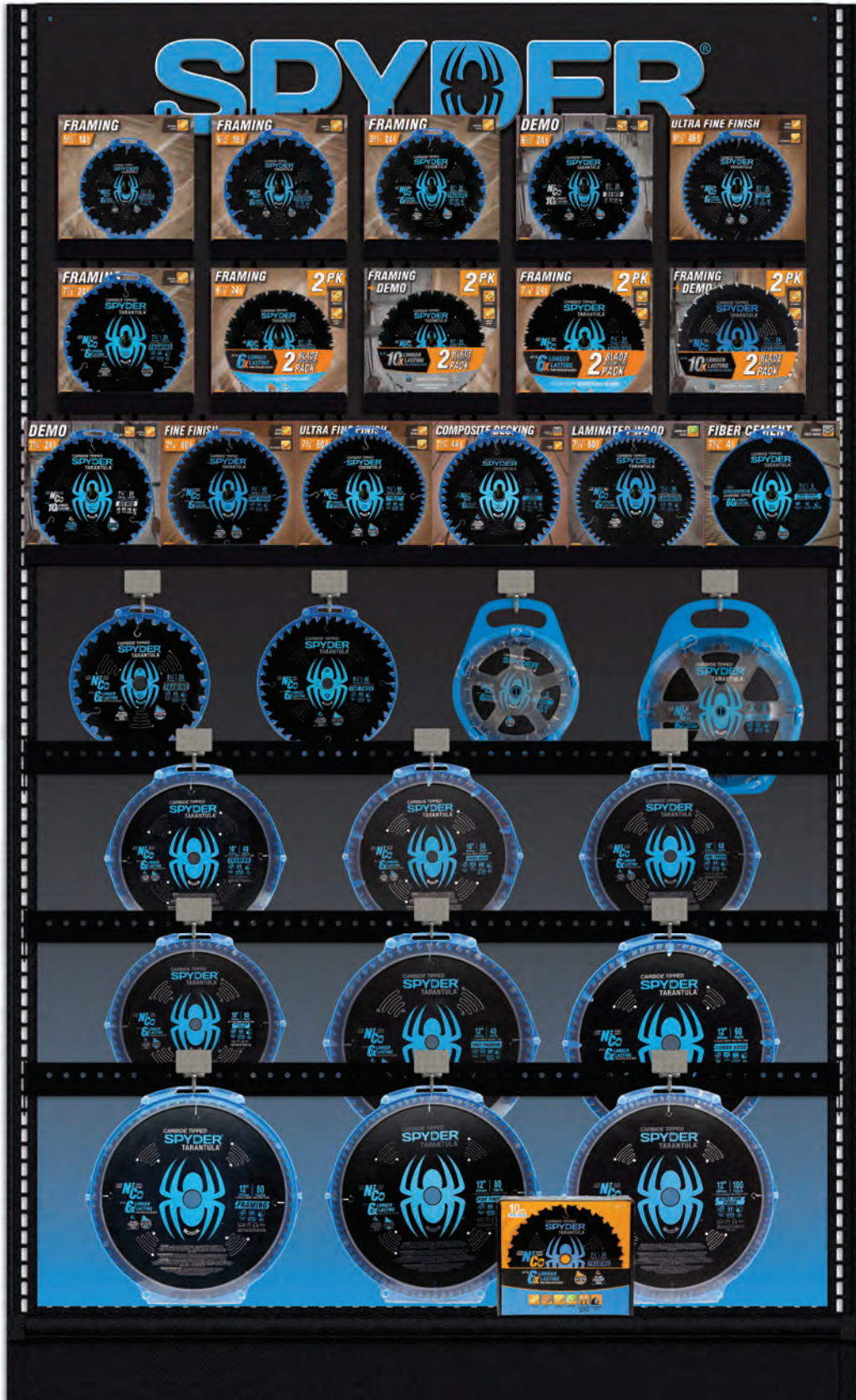

CIRCULAR SAWS

CIRCULAR SAW BLADES COMPLETE ASSORTMENT

13083

Item#	Description	QTY
13507	199 CS Small Hanging Bracket	1
13508	199 CS Medium Hanging Bracket	1
13509	199 CS Large Hanging Bracket	1
900760	4ft Spyder Gondola Graphic Backpanel	1
900712	4in Scan Hooks	15
900520	REORDER BACKCARDS	15
900720	Inline CS Shelf for Circular Saw Blades	16
13510	Inline CS Shelf Graphic Backers (set)	1
900760	Spyder Graphic Back Panel	1
13029	SPY 5-1/2in 18T Framing	2
13030	SPY 6-1/2in 18T Framing Blade	2
13004	SPY 6-1/2in 24T Framing Blade	2
13041	SPY 6-1/2in 24T Demolition Blade	2
13025	SPY 6-1/2in 48T - Ultra Fine Finish Blade	2
13028	SPY 7-1/4-in 4T PCD - Fiber Cement Board	2
13001	SPY 7-1/4in 24T Framing Blade	2
13006	SPY 7-1/4in 24T Demolition Blade	2
13007	SPY 7-1/4in 40T Fine Finish Blade	2
13019	SPY 7-1/4in 44T Decking	2
13018	SPY 7-1/4in 60T Ultra Fine Blade	2
13020	SPY 7-1/4in 60T Laminated Wood	2
13001-2	SPY 7-1/4in 24T Framing, 2pk	2
13004-2	SPY 6-1/2in 24T Framing, 2pk	2
13051	SPY 7-1/4in 24T Demo/Framing, 2pk	2
13061	SPY 6-1/2in 24T Demo/Framing, 2pk	2
13017	SPY 7-1/4in 24T Framing 10pc Pro Pack	2
13023	SPY 6in DADO Set	1
13024	SPY 8in DADO Set	1
13031	SPY 8-1/4in 24T Framing - Ring Pack	2
13058	SPY 8-1/4in 40T Framing - Ring Pack	2
13056	SPY 10in 40T General Purpose - Ring Pack	2
13021	SPY 10in 50T Combination Blade - Ring Pack	2
13053	SPY 10in 60T Fine Finish Blade - Ring Pack	2
13055	SPY 10in 80T Ultra Fine Finish Blade - Ring Pack	2
13059	SPY 12in 40T General Purpose Blade - Ring Pack	2
13022	SPY 12in 60T Combination Blade	2
13057	SPY 12in 60T General Purpose Blade - Ring Pack	2
13054	SPY 12in 80T Fine Finish Blade - Ring Pack	2
13027	SPY 12in 100T Ultra Fine Finish Blade - Ring Pack	2



Fixture view

CIRCULAR SAWS

32-IN CIRCULAR SAW BLADE ROLLING FLOORSTAND DISPLAY

900689

CIRCULAR SAWS

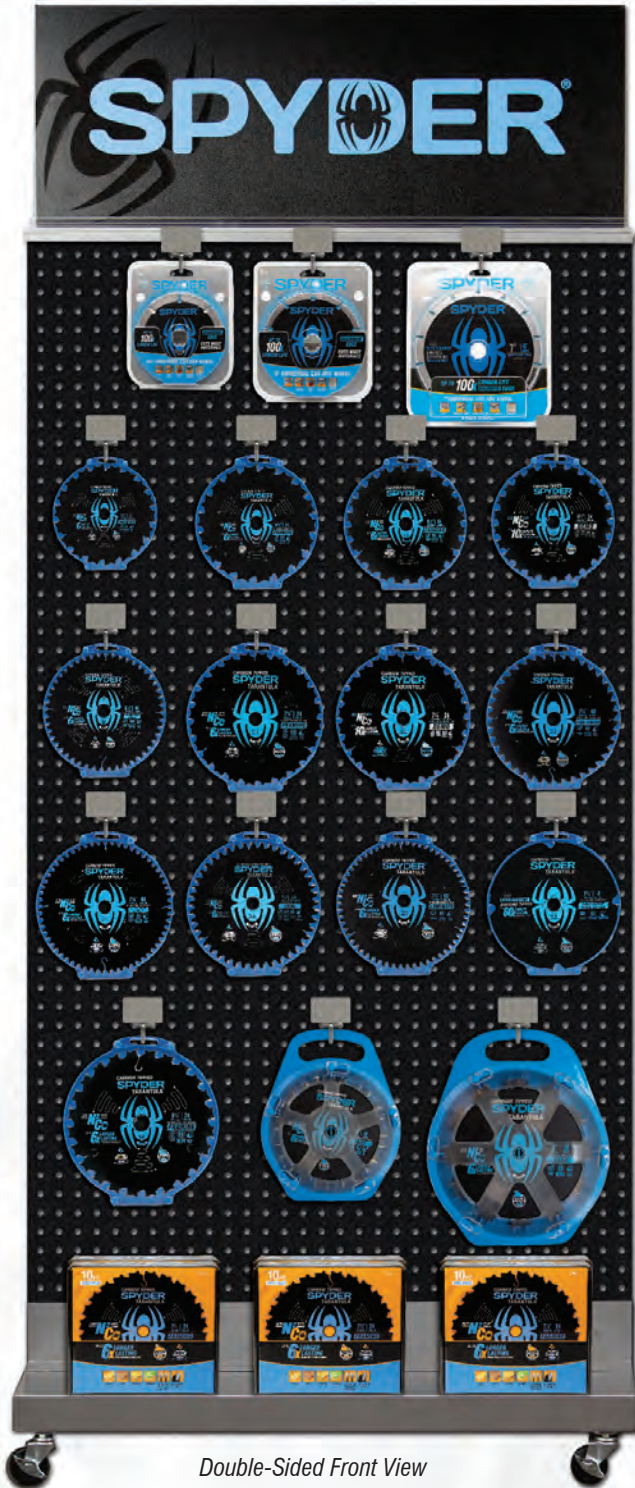

Double-Sided Front View



Double-Sided Back View

32-IN CIRCULAR SAW BLADE ROLLING FLOORSTAND DISPLAY (CONTINUED)

900689

Item#	Description	QTY
900585	SPYDER ROLLING DISPLAY PEGBOARD 32IN X 60IN BLACK	1
900586	SPYDER ROLLING DISPLAY BASE	1
900576	SPYDER ROLLING DISPLAY BRAND HEADER	1
900712	4in METAL WIRE SCAN HOOKS .225IN DIA THICK	28
900520	REORDER BACKCARDS	28
13029	SPY 5-1/2in 18T Framing	2
13030	SPY 6-1/2in 18T Framing Blade	2
13004	SPY 6-1/2in 24T Framing Blade	2
13041	SPY 6-1/2in 24T Demolition Blade	2
13025	SPY 6-1/2in 48T - Ultra Fine Finish Blade	2
13028	SPY 7-1/4-in 4T PCD - Fiber Cement Board	2
13001	SPY 7-1/4in 24T Framing Blade	2
13006	SPY 7-1/4in 24T Demolition Blade	2
13007	SPY 7-1/4in 40T Fine Finish Blade	2
13019	SPY 7-1/4in 44T Decking	2
13018	SPY 7-1/4in 60T Ultra Fine Blade	2
13020	SPY 7-1/4in 60T Laminated Wood	2
13017	SPY 7-1/4in 24T Framing 10pc Pro Pack	3
13023	SPY 6in DADO Set	2
13024	SPY 8in DADO Set	2
13058	Spyder 8-1/4in 40T Framing	2
13056	SPY 10in 40T General Purpose - Ring Pack	2
13021	SPY 10in 50T Combination Blade - Ring Pack	2
13053	SPY 10in 60T Fine Finish Blade - Ring Pack	2
13055	SPY 10in 80T Ultra Fine Finish Blade - Ring Pack	2
13022	SPY 12in 60T Combination Blade	2
13057	SPY 12in 60T General Purpose Blade - Ring Pack	2
13054	SPY 12in 80T Fine Finish Blade - Ring Pack	2
13027	SPY 12in 100T Ultra Fine Finish Blade - Ring Pack	2
14001	Diamond Cut-Off Wheel, 4.5"	2
14005	Diamond Cut-Off Wheel, 5"	2
14007	Diamond Cut-Off Wheel, 7"	2



CIRCULAR SAWS

STEEL CUTTING CIRCULAR SAW BLADES

Advanced Ultra Tough NiCo² (Nickel Cobalt) Teeth Specifically Designed for Clean Cuts in Steel & Other Metals

- Up to **35x more** cuts than bonded abrasive cutting wheels.
- Up to **10x faster** than bonded abrasive cutting wheels.
- Modified Triple Chip Grind (MTCG) results in dramatically cooler cutting and burr-free cuts with fewer sparks than those made with a bonded abrasive cutting wheel.
- Interfused anti-friction coating prevents blade binding and protects against heat and corrosion.
- Polymer-filled stabilization vents reduce noise and vibrations for a cleaner, straighter cut.
- Designed for use on metal cutting circular saws that feature high torque and low-RPM motors - not recommended for use on standard wood-cutting circular saws.

ADVANCED
ULTRA
TOUGH **NiCo²** NICKEL
COBALT

UP TO **10x** FASTER

UP TO **35x** MORE

Interfused
Anti-Friction
Coating

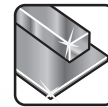

STAINLESS
STEEL



REBAR/ANGLE
IRON



ALL METAL

Advanced
Ultra Tough NiCo²
(Nickel Cobalt)
Cutting Teeth.



Polymer
Stabilization
Vents

STEEL CUTTING CIRCULAR SAW BLADES

13511

Item#	Description	QTY
900520	REORDER BACKCARDS	8
13500	Circular Saw Blade, 6-1/2" Dia, 48T, Steel Cutting	2
13501	Circular Saw Blade, 7-1/4" Dia, 36T, Steel Cutting	2
13502	Circular Saw Blade, 7-1/4" Dia, 56T, Steel Cutting	2
13503	Circular Saw Blade, 9" Dia, 46T, Steel Cutting	2
13504	Circular Saw Blade, 10" Dia, 50T, Steel Cutting	2
13505	Circular Saw Blade, 12" Dia, 60T, Steel Cutting	2
13506	Circular Saw Blade, 14" Dia, 72T, Steel Cutting	2

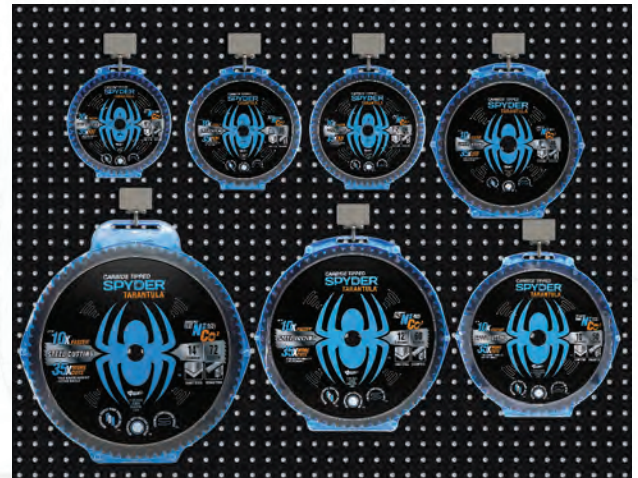

STINGER™ MACH-BLUE™ HIGH-SPEED STEEL (HSS) DRILL BITS

High-Performance Metal & Wood Drilling Bits

- Up to **100x more holes** than titanium or black oxide drill bits.
- Up to **8x faster** than titanium or black oxide drill bits.
- Proprietary Mach-Blue™ Armor Plating is a super hard surface that retains sharper cutting edges, and reduces heat build-up and cutting friction – resulting in faster cuts and exceptionally long drill life.
- Impact-rated 1/4" speed hex won't slip in conventional 3-jaw chucks and ideal for use in quick-change impacting power tools.
- Optimized 137° self-centering split point cutting geometry won't walk or wander – even on pre-hardened or curved surfaces.
- Advanced M-Series alloy tool steel construction and proprietary heat treatment increase drill bit durability, rigidity and breakage resistance.
- Ideal for drilling wood with nails, stainless steel, mild steel, aluminum, stacked materials and other tough-to-drill alloys.
- Made in the USA.



UP TO
8x
FASTER

UP TO
100x
MORE

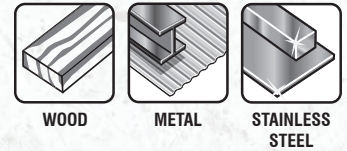

Proprietary Hard Surface Retains Cutting Edges, Reduces Heat and Friction.

1/4" Speed Hex Won't Slip in the Chuck, Fits Quick-Change Impact Drivers.



SPEED HEX

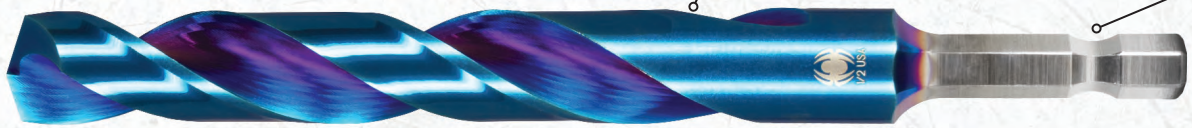

MACH-BLUE™ DRILL BITS

19320

Item#	Description	QTY
900520	REORDER BACKCARDS	20
19017	10pc Mach-Blue Hex Shank Drill Bit Set	5
19000	1/16" Mach-Blue Hex Shank Drill Bit	10
19001	5/64" Mach-Blue Hex Shank Drill Bit	10
19002	3/32" Mach-Blue Hex Shank Drill Bit	10
19003	7/64" Mach-Blue Hex Shank Drill Bit	10
19004	1/8" Mach-Blue Hex Shank Drill Bit	10
19005	9/64" Mach-Blue Hex Shank Drill Bit	10
19006	5/32" Mach-Blue Hex Shank Drill Bit	10
19007	11/64" Mach-Blue Hex Shank Drill Bit	10
19008	3/16" Mach-Blue Hex Shank Drill Bit	10
19009	13/64" Mach-Blue Hex Shank Drill Bit	10
19010	7/32" Mach-Blue Hex Shank Drill Bit	10
19011	15/64" Mach-Blue Hex Shank Drill Bit	10
19012	1/4" Mach-Blue Hex Shank Drill Bit	10
19013	5/16" Mach-Blue Hex Shank Drill Bit	5
19014	3/8" Mach-Blue Hex Shank Drill Bit	5
19015	7/16" Mach-Blue Hex Shank Drill Bit	5
19016	1/2" Mach-Blue Hex Shank Drill Bit	5

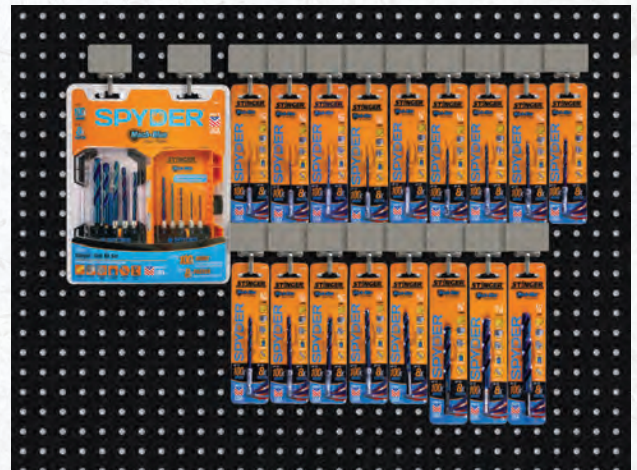

MACH-BLUE™

STINGER™ MACH-BLUE™ STEP DRILL BITS

Consistently Drill a Wide Range of Holes with a Single Drill Bit

- Up to **50x more** holes than titanium or black oxide drill bits.
- Up to **2x faster** than titanium or black oxide step drill bits.
- Proprietary Mach-Blue™ Armor Plating is a super hard surface that retains sharper cutting edges, and reduces heat build-up and cutting friction, resulting in faster cuts and exceptionally long drill life.
- Impact-rated 1/4" speed hex won't slip in conventional 3-jaw chucks and ideal for use in quick-change impacting power tools.
- Optimized 135° self-centering split point cutting geometry won't walk or wander - even on pre-hardened or curved surfaces.
- Advanced M-Series alloy tool steel construction and proprietary heat treatment increase drill bit durability, rigidity, and breakage resistance.
- Ideal for drilling wood with nails, stainless steel, mild steel, aluminum, stacked materials and other tough-to-drill alloys.
- Made in the USA.



UP TO
50x
MORE

UP TO
2x
FASTER

Proprietary Hard Surface Retains Cutting Edges, Reduces Heat and Friction.



METAL

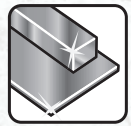

STAINLESS STEEL

1/4" Speed Hex Won't Slip in the Chuck, Fits Quick-Change Impact Drivers.

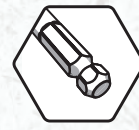

SPEED HEX

135° No wandering, self-centering split point



MACH-BLUE™ STEP DRILL BITS

19325

Item#	Description	QTY
900520	REORDER BACKCARDS	9
19025	2pc Step Bit Set, Mach-Blue Hex Shank, (1/8" - 1/2" & 3/16" - 7/8")	3
19019	SPY 13 Step Bit, Mach-Blue Hex Shank, 1/8" - 1/2" #1	3
19020	SPY 6 Step Bit, Mach-Blue Hex Shank, 3/16" - 1/2"	3
19021	SPY 9 Step Bit, Mach-Blue Hex Shank, 1/4" - 3/4"	3
19022	SPY 12 Step Bit, Mach-Blue Hex Shank, 3/16" - 7/8" #4	3
19023	SPY 16 Step Bit, Mach-Blue Hex Shank, 3/16" - 1-1/8"	3
19024	SPY 10 Step Bit, Mach-Blue Hex Shank, 1/4" - 1-3/8"	3
19071	SPY 8 Step Bit, Mach-Blue Hex Shank, 1/4" - 1"	3

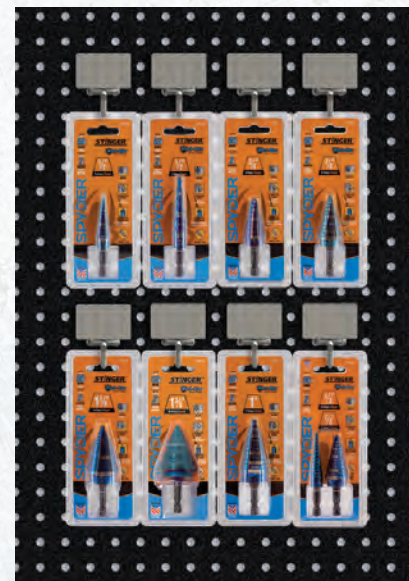

MACH-BLUE™

MACH-BLUE™ IMPACT-RATED DRIVER BITS

High-Performance Bits for Demanding Fastener Applications

- Up to **70x longer** life than standard impact-rated driver bits.
- Up to **33% stronger** IMPACTive™ alloy steel extends tool life in high-torque impact applications.
- Mach-Blue™ Tough Tip Technology - Proprietary plating strengthens tip surfaces for increased wear and extreme corrosion resistance.
- Precision-fitting tips are machined to resist cam-out, twisting and breaking.
- Progressive Torsion Zone actively flexes to dissipate peak impact forces preventing fastener recess damage and tip breakage.
- Multi-stage heat treatment process provides an optimal blend of bit hardness and durability.
- Impact-rated 1/4" speed hex is ideal for use in high-torque impact drivers and conventional rotary drills.

UP TO
70x
LONGER

UP TO
33%
STRONGER

Impact-Rated
1/4" Speed Hex

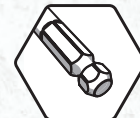

SPEED HEX



IMPACTS
& DRILLS

PROGRESSIVE TORSION ZONE

Actively Flexes to Dissipate Peak Impact Forces

TOUGH TIP TECHNOLOGY



Precision-Fitting Tips Resist Cam-Out, Twisting and Breaking. IMPACTive™ Alloy Steel Extends Tool Life.



MACH-BLUE™ DRIVER BITS

19323

Item#	Description	QTY
900520	REORDER BACKCARDS	75
19027	8-Piece 1/4" x 1" Impact Bit Set	3
19028	7-Piece 1/4" x 2" Impact Bit Set	3
19029	SPY Mach-Blue 25-pc Impact Bit Set	3
19030	SPY Mach-Blue 30-pc Impact Bit Set	3
19031	SPY 15-Piece Drill and Impact Set	3
19032	SPY 30-Piece Drill and Impact Set	3
19033	SPY 2-Piece 1/4-in x 1-in PH1	3
19034	SPY 2-Piece 1/4-in x 1-in PH2	3
19035	SPY 2-Piece 1/4-in x 1-in PH3	3
19036	SPY 2-Piece 1/4-in x 1-in SQ1	3
19037	SPY 2-Piece 1/4-in x 1-in SQ2	3
19038	SPY 2-Piece 1/4-in x 1-in SQ3	3
19039	SPY 2-Piece 1/4-in x 1-in T10	3
19040	SPY 2-Piece 1/4-in x 1-in T15	3
19041	SPY 2-Piece 1/4-in x 1-in T20	3
19042	SPY 2-Piece 1/4-in x 1-in T25	3
19043	SPY 2-Piece 1/4-in x 1-in T30	3
19044	SPY 2-Piece 1/4-in x 1-in T40	3
19045	SPY 2-Piece 1/4-in x 2-in PH1	3
19046	SPY 2-Piece 1/4-in x 2-in PH2	3

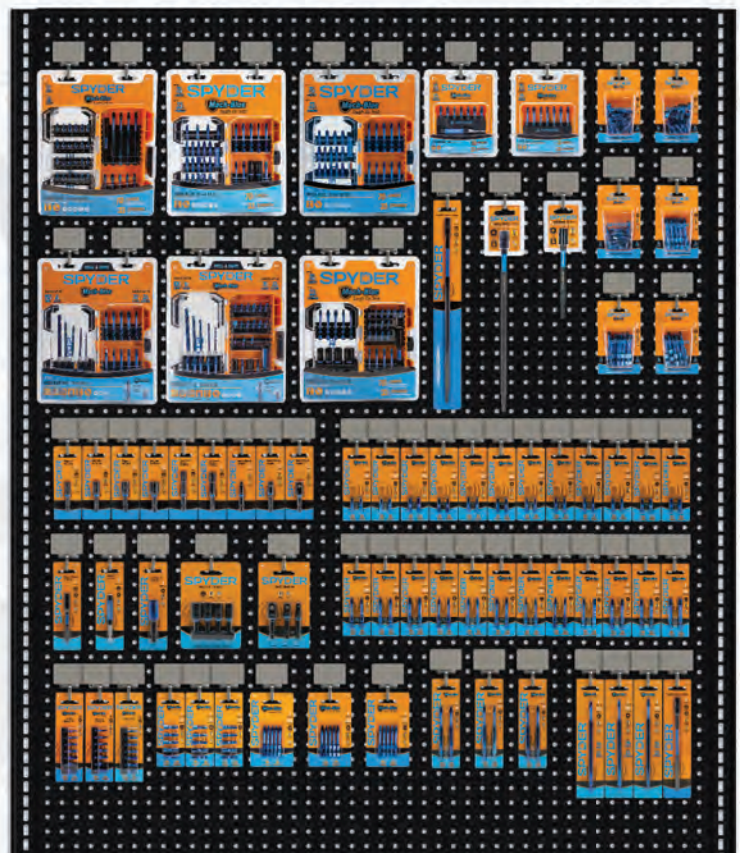

MACH-BLUE™

MACH-BLUE™ DRIVER BIT (CONTINUED)

19323

Item#	Description	QTY
19047	SPY 2-Piece 1/4-in x 2-in PH3	3
19048	SPY 2-Piece 1/4-in x 2-in SQ1	3
19049	SPY 2-Piece 1/4-in x 2-in SQ2	3
19050	SPY 2-Piece 1/4-in x 2-in SQ3	3
19051	SPY 2-Piece 1/4-in x 2-in T10	3
19052	SPY 2-Piece 1/4-in x 2-in T15	3
19053	SPY 2-Piece 1/4-in x 2-in T20	3
19054	SPY 2-Piece 1/4-in x 2-in T25	3
19055	SPY 2-Piece 1/4-in x 2-in T30	3
19056	SPY 2-Piece 1/4-in x 2-in T40	3
19057	SPY 2-Piece 1/4-in x 3-1/2-in PH2	3
19058	SPY 2-Piece 1/4-in x 3-1/2-in SQ2	3
19059	SPY 2-Piece 1/4-in x 3-1/2-in T25	3
19060	SPY 1-Piece 1/4-in x 6-in PH2	3
19061	SPY 1-Piece 1/4-in x 6-in SQ2	3
19062	SPY 1-Piece 1/4-in x 6-in T25	3
19063	SPY 4-Piece 1/4-in Nut Driver Set	3
19064	SPY 3-Piece 1/4-in Socket Adapter Set	3
19065	SPY 7-Piece 1/4-in x 1-in SAE Impact Set	3
19066	SPY 7-Piece 1/4-in x 1-in Metric Impact Set	3
19067	SPY 7-Piece 1/4-in x 1-in T-Impact Set	3
19068	SPY 1/4-in x 3-in Hex Magnetic Torsion Extension	3
19069	SPY 1/4-in x 3-in Hex Magnetic Bit Extension	3
19070	SPY 1/4-in x 3-in Quick Change Bit Extension	3
19072	SPY 25-Piece 1/4-in x 1-in PH2	3
19073	SPY 25-Piece 1/4-in x 1-in T25	3

Item#	Description	QTY
19074	SPY 25-Piece 1/4-in x 1-in SQ2	3
19075	SPY 15-Piece 1/4-in x 2-in PH2	3
19076	SPY 15-Piece 1/4-in x 2-in T25	3
19077	SPY 15-Piece 1/4-in x 2-in SQ2	3
19078	SPY Mach-Blue 28-pc Impact Bit Set	3
19079	SPY Mach-Blue 34-pc Impact Bit Set	3
19080	SPY 1/4-in x 6-in Hex Magnetic Bit Holder	3
19081	SPY 1/4-in x 12-in Hex Magnetic Bit Holder	3
19082	SPY 1/4-in x 6-in Quick Change Bit Holder	3
19083	SPY 1/4-in x 12-in Quick Change Bit Holder	3
19084	SPY 5-Piece 1/4-in x 1-in PH2	3
19085	SPY 5-Piece 1/4-in x 1-in SQ2	3
19086	SPY 5-Piece 1/4-in x 1-in T25	3
19087	SPY 5-Piece 1/4-in x 2-in PH2	3
19088	SPY 5-Piece 1/4-in x 2-in SQ2	3
19089	SPY 5-Piece 1/4-in x 2-in T25	3
19090	SPY 1/4-in Nut Driver	3
19091	SPY 5/16-in Nut Driver	3
19092	SPY 3/8-in Nut Driver	3
19093	SPY 7/16-in Nut Driver	3
19094	SPY 1/4-in Nut Driver - Deep	3
19095	SPY 5/16-in Nut Driver - Deep	3
19096	SPY Socket Adapter 1/4-in x 1/4-in SQ	3
19097	SPY Socket Adapter 1/4-in x 3/8-in SQ	3
19098	SPY Socket Adapter 1/4-in x 1/2-in SQ	3

IMPACT EXTENSIONS & BIT HOLDERS

19324

Item#	Description	QTY
900520	REORDER BACKCARDS	8
19068	SPY 1/4-in x 3-in Hex Magnetic Torsion Bit Holder	3
19069	SPY 1/4-in x 3-in Hex Magnetic Bit Extension	3
19070	SPY 1/4-in x 3-in Quick Change Bit Extension	3
19080	SPY 1/4-in x 6-in Hex Magnetic Torsion Bit Holder	3
19081	SPY 1/4-in x 12-in Hex Magnetic Torsion Bit Holder	3
19082	SPY 1/4-in x 6-in Quick Change Bit Holder	3
19083	SPY 1/4-in x 12-in Quick Change Bit Holder	3

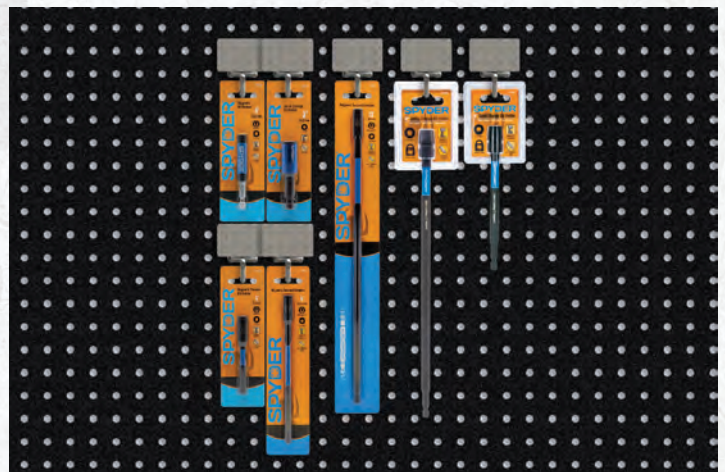

MACH-BLUE™ DRILL & DRIVER BITS

19321

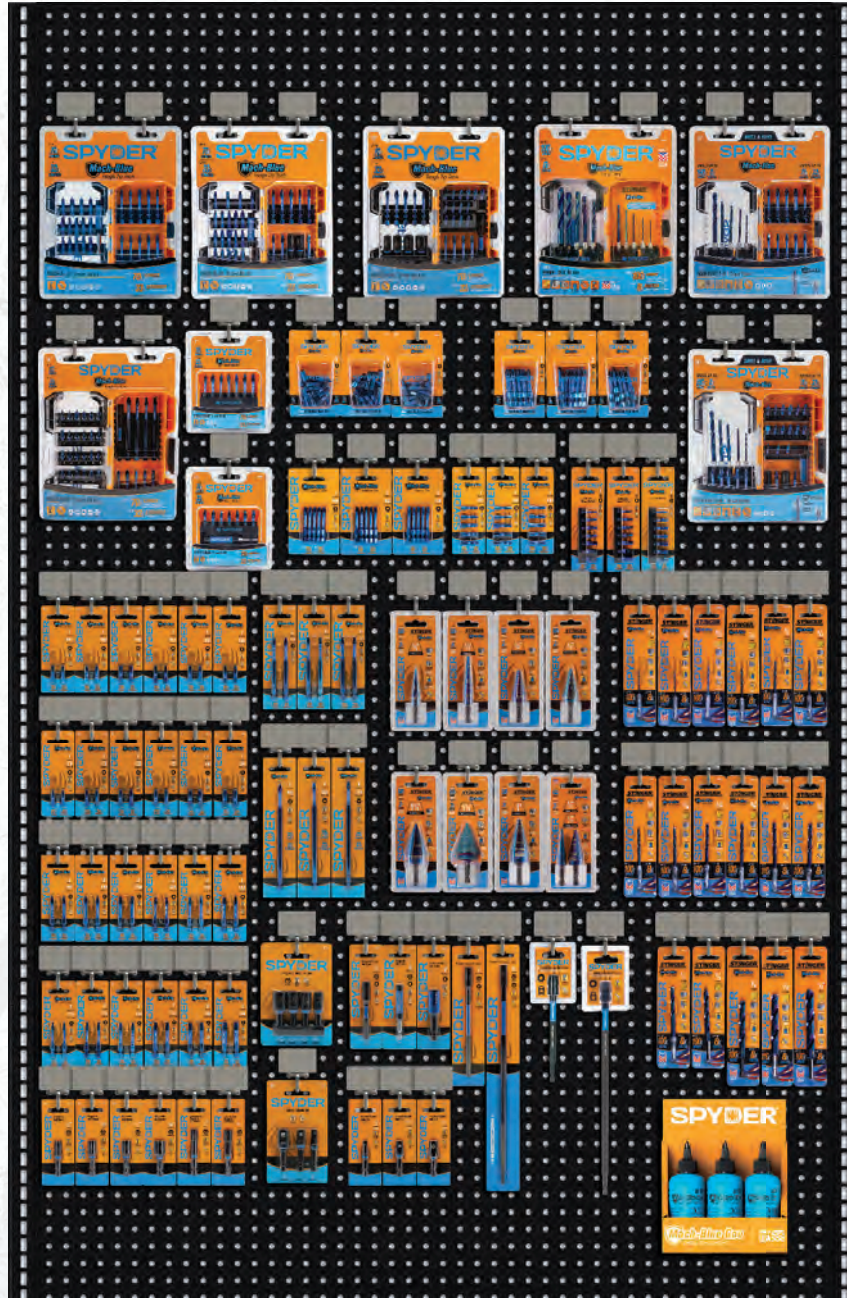

Item#	Description	QTY
900760	4ft Spyder Gondola Graphic Backpanel	1
900712	4in METAL WIRE SCAN HOOKS .225IN DIA THICK	110
900520	REORDER BACKCARDS	110
19017	10pc Mach-Blue Hex Shank Drill Bit Set	5
19000	1/16" Mach-Blue Hex Shank Drill Bit	10
19001	5/64" Mach-Blue Hex Shank Drill Bit	10
19002	3/32" Mach-Blue Hex Shank Drill Bit	10
19003	7/64" Mach-Blue Hex Shank Drill Bit	10

19004	1/8" Mach-Blue Hex Shank Drill Bit	10
19005	9/64" Mach-Blue Hex Shank Drill Bit	10
19006	5/32" Mach-Blue Hex Shank Drill Bit	10
19007	11/64" Mach-Blue Hex Shank Drill Bit	10
19008	3/16" Mach-Blue Hex Shank Drill Bit	10
19009	13/64" Mach-Blue Hex Shank Drill Bit	10
19010	7/32" Mach-Blue Hex Shank Drill Bit	10
19011	15/64" Mach-Blue Hex Shank Drill Bit	10
19012	1/4" Mach-Blue Hex Shank Drill Bit	10

MACH-BLUE™ DRILL AND DRIVER BITS (CONTINUED)

19321

Item#	Description	QTY
19013	5/16" Mach-Blue Hex Shank Drill Bit	5
19014	3/8" Mach-Blue Hex Shank Drill Bit	5
19015	7/16" Mach-Blue Hex Shank Drill Bit	5
19016	1/2" Mach-Blue Hex Shank Drill Bit	5
19027	SPY 8-Piece 1/4-in x 1-in Impact Bit Set	3
19028	SPY 7-Piece 1/4-in x 2-in Impact Bit Set	3
19029	SPY Mach-Blue 25-pc Impact Bit Set	3
19030	SPY Mach-Blue 30-pc Impact Bit Set	3
19031	SPY 15-Piece Drill and Impact Set	3
19032	SPY 30-Piece Drill and Impact Set	3
19033	SPY 2-Piece 1/4-in x 1-in PH1	3
19034	SPY 2-Piece 1/4-in x 1-in PH2	3
19035	SPY 2-Piece 1/4-in x 1-in PH3	3
19036	SPY 2-Piece 1/4-in x 1-in SQ1	3
19037	SPY 2-Piece 1/4-in x 1-in SQ2	3
19038	SPY 2-Piece 1/4-in x 1-in SQ3	3
19039	SPY 2-Piece 1/4-in x 1-in T10	3
19040	SPY 2-Piece 1/4-in x 1-in T15	3
19041	SPY 2-Piece 1/4-in x 1-in T20	3
19042	SPY 2-Piece 1/4-in x 1-in T25	3
19043	SPY 2-Piece 1/4-in x 1-in T30	3
19044	SPY 2-Piece 1/4-in x 1-in T40	3
19045	SPY 2-Piece 1/4-in x 2-in PH1	3
19046	SPY 2-Piece 1/4-in x 2-in PH2	3
19047	SPY 2-Piece 1/4-in x 2-in PH3	3
19048	SPY 2-Piece 1/4-in x 2-in SQ1	3
19049	SPY 2-Piece 1/4-in x 2-in SQ2	3
19050	SPY 2-Piece 1/4-in x 2-in SQ3	3
19051	SPY 2-Piece 1/4-in x 2-in T10	3
19052	SPY 2-Piece 1/4-in x 2-in T15	3
19053	SPY 2-Piece 1/4-in x 2-in T20	3
19054	SPY 2-Piece 1/4-in x 2-in T25	3
19055	SPY 2-Piece 1/4-in x 2-in T30	3
19056	SPY 2-Piece 1/4-in x 2-in T40	3
19057	SPY 2-Piece 1/4-in x 3-1/2-in PH2	3
19058	SPY 2-Piece 1/4-in x 3-1/2-in SQ2	3
19059	SPY 2-Piece 1/4-in x 3-1/2-in T25	3
19060	SPY 1-Piece 1/4-in x 6-in PH2	3
19061	SPY 1-Piece 1/4-in x 6-in SQ2	3
19062	SPY 1-Piece 1/4-in x 6-in T25	3
19063	SPY 4-Piece 1/4-in Nut Driver Set	3
19064	SPY 3-Piece 1/4-in Socket Adapter Set	3
19065	SPY 7-Piece 1/4-in x 1-in SAE Impact Set	3

Item#	Description	QTY
19066	SPY 7-Piece 1/4-in x 1-in Metric Impact Set	3
19067	SPY 7-Piece 1/4-in x 1-in T-Impact Set	3
19068	SPY 1/4-in x 3-in Hex Magnetic Torsion Extension	3
19069	SPY 1/4-in x 3-in Hex Magnetic Bit Extension	3
19070	SPY 1/4-in x 3-in Quick Change Bit Extension	3
19072	SPY 25-Piece 1/4-in x 1-in PH2	3
19073	SPY 25-Piece 1/4-in x 1-in T25	3
19074	SPY 25-Piece 1/4-in x 1-in SQ2	3
19075	SPY 15-Piece 1/4-in x 2-in PH2	3
19076	SPY 15-Piece 1/4-in x 2-in T25	3
19077	SPY 15-Piece 1/4-in x 2-in SQ2	3
19078	SPY Mach-Blue 28-pc Impact Bit Set	3
19079	SPY Mach-Blue 34-pc Impact Bit Set	3
19080	SPY 1/4-in x 6-in Hex Magnetic Bit Holder	3
19081	SPY 1/4-in x 12-in Hex Magnetic Bit Holder	3
19082	SPY 1/4-in x 6-in Quick Change Bit Holder	3
19083	SPY 1/4-in x 12-in Quick Change Bit Holder	3
19084	SPY 5-Piece 1/4-in x 1-in PH2	3
19085	SPY 5-Piece 1/4-in x 1-in SQ2	3
19086	SPY 5-Piece 1/4-in x 1-in T25	3
19087	SPY 5-Piece 1/4-in x 2-in PH2	3
19088	SPY 5-Piece 1/4-in x 2-in SQ2	3
19089	SPY 5-Piece 1/4-in x 2-in T25	3
19090	SPY 1/4-in Nut Driver	3
19091	SPY 5/16-in Nut Driver	3
19092	SPY 3/8-in Nut Driver	3
19093	SPY 7/16-in Nut Driver	3
19094	SPY 1/4-in Nut Driver - Deep	3
19095	SPY 5/16-in Nut Driver - Deep	3
19096	SPY Socket Adapter 1/4-in x 1/4-in SQ	3
19097	SPY Socket Adapter 1/4-in x 3/8-in SQ	3
19098	SPY Socket Adapter 1/4-in x 1/2-in SQ	3
19025	Spyder 2pc Step Bit Set, Mach-Blue Hex Shank, (1/8"-1/2" & 3/16"-7/8")	3
19019	Spyder 13 Step Bit, Mach-Blue Hex Shank, 1/8" - 1/2" #1	3
19020	Spyder 6 Step Bit, Mach-Blue Hex Shank, 3/16" - 1/2"	3
19021	Spyder 9 Step Bit, Mach-Blue Hex Shank, 1/4" - 3/4"	3
19022	Spyder 12 Step Bit, Mach-Blue Hex Shank, 3/16" - 7/8" #4	3
19023	Spyder 16 Step Bit, Mach-Blue Hex Shank, 3/16" - 1-1/8"	3
19024	Spyder 10 Step Bit, Mach-Blue Hex Shank, 1/4" - 1-3/8"	3
19071	Spyder 8 Step Bit, Mach-Blue Hex Shank, 1/4" - 1"	3
900709-COUNTER	Mach-Blue Goo Cutting Lubricant, 6oz Counter	1

32-IN MACH-BLUE™ DRIVER BIT ROLLING FLOORSTAND DISPLAY

19326

Item#	Description	QTY
900585	SPYDER ROLLING DISPLAY PEGBOARD 32IN X 60IN BLACK	1
900586	SPYDER ROLLING DISPLAY BASE	1
900576	SPYDER ROLLING DISPLAY BRAND HEADER	1
900712	4in METAL WIRE SCAN HOOKS .225IN DIA THICK	80
900520	REORDER BACKCARDS	80
19027	8-Piece 1/4" x 1" Impact Bit Set	3
19028	7-Piece 1/4" x 2" Impact Bit Set	3
19029	SPY Mach-Blue 25-pc Impact Bit Set	3
19030	SPY Mach-Blue 30-pc Impact Bit Set	3
19031	SPY 15-Piece Drill and Impact Set	3
19032	SPY 30-Piece Drill and Impact Set	3
19033	SPY 2-Piece 1/4-in x 1-in PH1	3
19034	SPY 2-Piece 1/4-in x 1-in PH2	3
19035	SPY 2-Piece 1/4-in x 1-in PH3	3
19036	SPY 2-Piece 1/4-in x 1-in SQ1	3
19037	SPY 2-Piece 1/4-in x 1-in SQ2	3
19038	SPY 2-Piece 1/4-in x 1-in SQ3	3
19039	SPY 2-Piece 1/4-in x 1-in T10	3
19040	SPY 2-Piece 1/4-in x 1-in T15	3
19041	SPY 2-Piece 1/4-in x 1-in T20	3
19042	SPY 2-Piece 1/4-in x 1-in T25	3
19043	SPY 2-Piece 1/4-in x 1-in T30	3
19044	SPY 2-Piece 1/4-in x 1-in T40	3
19045	SPY 2-Piece 1/4-in x 2-in PH1	3
19046	SPY 2-Piece 1/4-in x 2-in PH2	3
19047	SPY 2-Piece 1/4-in x 2-in PH3	3
19048	SPY 2-Piece 1/4-in x 2-in SQ1	3
19049	SPY 2-Piece 1/4-in x 2-in SQ2	3
19050	SPY 2-Piece 1/4-in x 2-in SQ3	3
19051	SPY 2-Piece 1/4-in x 2-in T10	3
19052	SPY 2-Piece 1/4-in x 2-in T15	3
19053	SPY 2-Piece 1/4-in x 2-in T20	3
19054	SPY 2-Piece 1/4-in x 2-in T25	3
19055	SPY 2-Piece 1/4-in x 2-in T30	3
19056	SPY 2-Piece 1/4-in x 2-in T40	3
19057	SPY 2-Piece 1/4-in x 3-1/2-in PH2	3
19058	SPY 2-Piece 1/4-in x 3-1/2-in SQ2	3
19059	SPY 2-Piece 1/4-in x 3-1/2-in T25	3
19060	SPY 1-Piece 1/4-in x 6-in PH2	3
19061	SPY 1-Piece 1/4-in x 6-in SQ2	3
19062	SPY 1-Piece 1/4-in x 6-in T25	3
19063	SPY 4-Piece 1/4-in Nut Driver Set	3

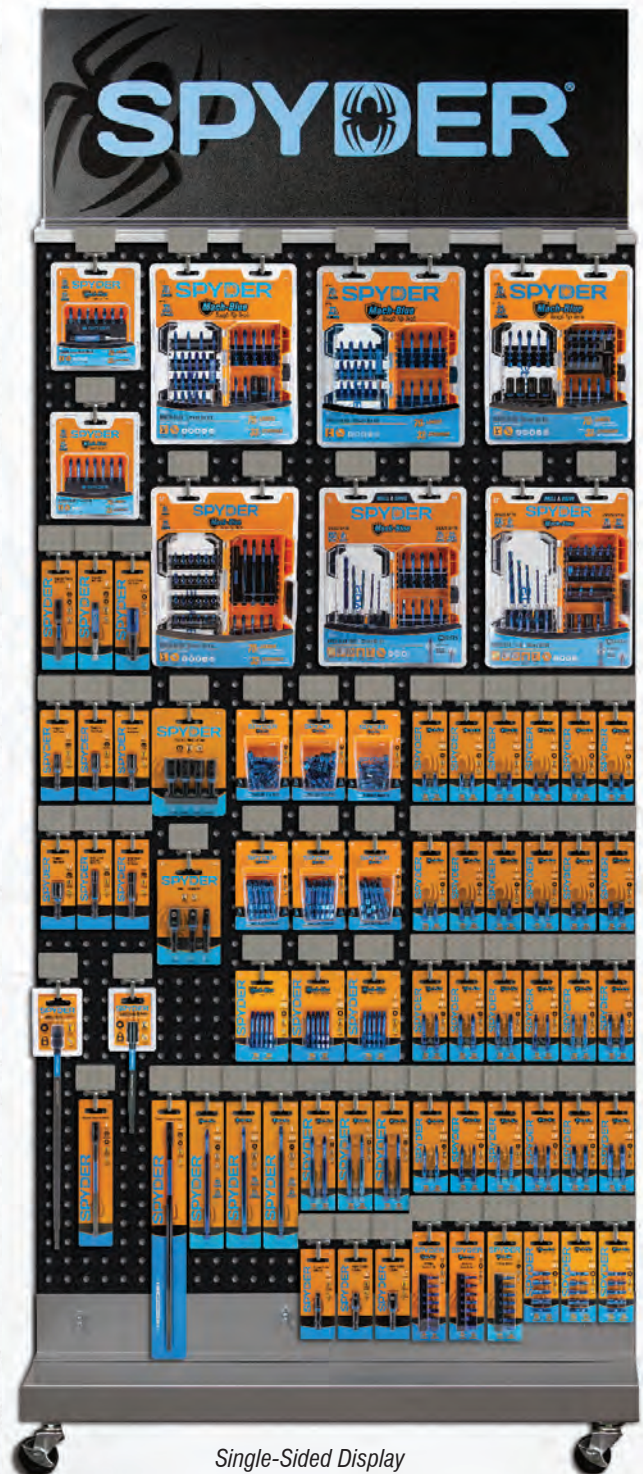

Single-Sided Display

MACH-BLUE™

32-IN MACH-BLUE™ DRIVER BIT ROLLING FLOORSTAND DISPLAY (CONTINUED)

19326

Item#	Description	QTY
19064	SPY 3-Piece 1/4-in Socket Adapter Set	3
19065	SPY 7-Piece 1/4-in x 1-in SAE Impact Set	3
19066	SPY 7-Piece 1/4-in x 1-in Metric Impact Set	3
19067	SPY 7-Piece 1/4-in x 1-in T-Impact Set	3
19068	SPY 1/4-in x 3-in Hex Magnetic Torsion Extension	3
19069	SPY 1/4-in x 3-in Hex Magnetic Bit Extension	3
19070	SPY 1/4-in x 3-in Quick Change Bit Extension	3
19072	SPY 25-Piece 1/4-in x 1-in PH2	3
19073	SPY 25-Piece 1/4-in x 1-in T25	3
19074	SPY 25-Piece 1/4-in x 1-in SQ2	3
19075	SPY 15-Piece 1/4-in x 2-in PH2	3
19076	SPY 15-Piece 1/4-in x 2-in T25	3
19077	SPY 15-Piece 1/4-in x 2-in SQ2	3
19078	SPY Mach-Blue 28-pc Impact Bit Set	3
19079	SPY Mach-Blue 34-pc Impact Bit Set	3
19080	SPY 1/4-in x 6-in Hex Magnetic Bit Holder	3
19081	SPY 1/4-in x 12-in Hex Magnetic Bit Holder	3
19082	SPY 1/4-in x 6-in Quick Change Bit Holder	3
19083	SPY 1/4-in x 12-in Quick Change Bit Holder	3
19084	SPY 5-Piece 1/4-in x 1-in PH2	3
19085	SPY 5-Piece 1/4-in x 1-in SQ2	3
19086	SPY 5-Piece 1/4-in x 1-in T25	3
19087	SPY 5-Piece 1/4-in x 2-in PH2	3
19088	SPY 5-Piece 1/4-in x 2-in SQ2	3
19089	SPY 5-Piece 1/4-in x 2-in T25	3
19090	SPY 1/4-in Nut Driver	3
19091	SPY 5/16-in Nut Driver	3
19092	SPY 3/8-in Nut Driver	3
19093	SPY 7/16-in Nut Driver	3
19094	SPY 1/4-in Nut Driver - Deep	3
19095	SPY 5/16-in Nut Driver - Deep	3
19096	SPY Socket Adapter 1/4-in x 1/4-in SQ	3
19097	SPY Socket Adapter 1/4-in x 3/8-in SQ	3
19098	SPY Socket Adapter 1/4-in x 1/2-in SQ	3



MACH-BLUE™

PRO POWERED TOOLS

30PC MACH-BLUE™ DRIVER BIT KIT FLOORSTAND

900762

Item#	Description	QTY
19030	SPY 30pc MACH-BLUE IIMPACT BIT SET	30



MACH-BLUE™ DRILL/DRIVE BIT KIT FLOORSTAND

900763

Item#	Description	QTY
19017	SPY 10PC MACH-BLUE HEX SHANK DRILL BIT SET	20
19030	SPY 30PC MACH-BLUE IIMPACT BIT SET	20



6PC SPADE BIT FLOORSTAND

900761

Item#	Description	QTY
11002	Spyder 6pc Spade Bit Kit	30



6PC SPADE BIT COUNTER DISPLAY

11038

Item#	Description	QTY
11002	Spyder 6pc Spade Bit Kit	6



MERCHANDISING

PRO POWERED TOOLS

7-1/4-IN 24T FRAMING BLADE COUNTER DISPLAY

13086

Item#	Description	QTY
13001	Spyder 7-1/4" 24T FRAMING CS Blade	10



7-1/4-IN 24T DEMO BLADE COUNTER DISPLAY

13087

Item#	Description	QTY
13006	Spyder 7-1/4" 24T DEMO CS Blade	10

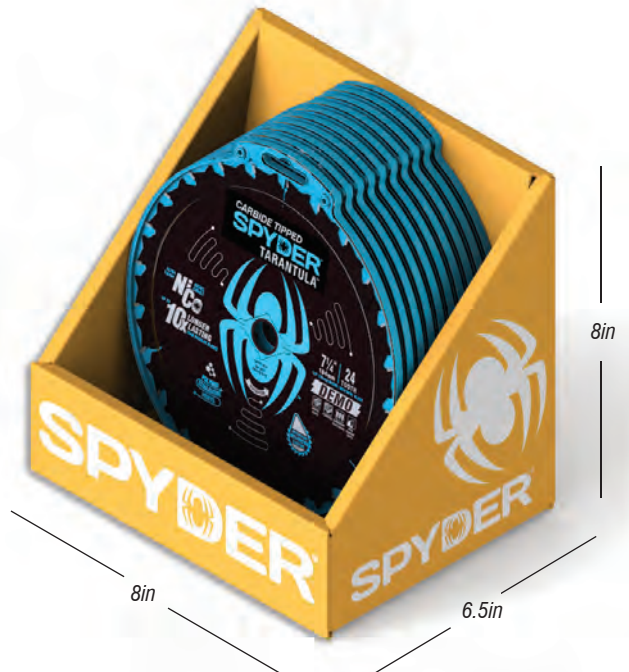

MERCHANDISING

7-1/4-IN 24T FRAMING BLADE 2PC COUNTER DISPLAY

13088

Item#	Description	QTY
13001-2	Spyder 7-1/4" 24T Framing Blade 2pc	10



6-1/2-IN 24T FRAMING BLADE COUNTER DISPLAY

13090

Item#	Description	QTY
13004	6-1/2" 24T FRAMING BLADE	10



MERCHANDISING

PRO POWERED TOOLS

7-1/4-IN 24T DEMO BLADE 2PC COUNTER DISPLAY

13089

Item#	Description	QTY
13051	Spyder 7-1/4" 24T Demo/Framing Blade 2pc	10



HOLE SAW KIT FLOORSTAND

900764

Item#	Description	QTY
600938	Spyder 18pc TCT Hole Saw Kit	8
600887	Spyder 13pc BIM Hole Saw Kit	8
600925	Spyder 9pc Tarantula Hole Saw Kit	8



MERCHANDISING

18PC TCT HOLE SAW KIT TRAY, 3 PACK

900765

Item#	Description	QTY
600938	Spyder 18pc TCT Hole Saw Kit	3

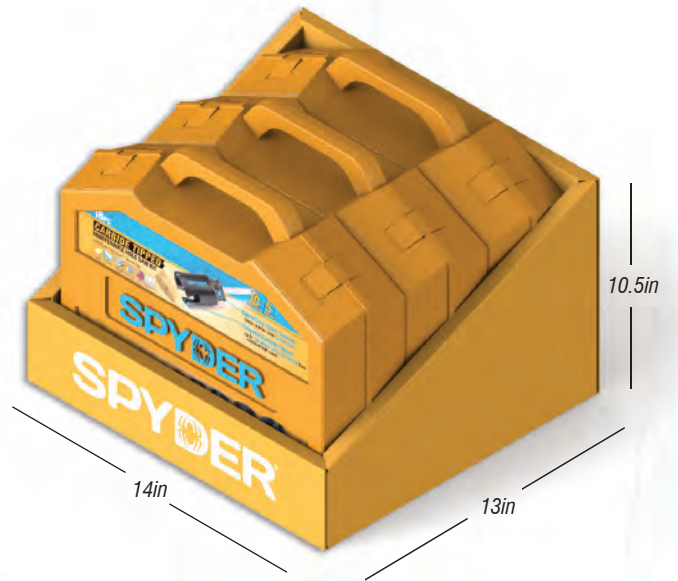

13PC BI-METAL HOLE SAW KIT TRAY, 3 PACK

900766

Item#	Description	QTY
600887	Spyder 13pc BIM Hole Saw Kit	3

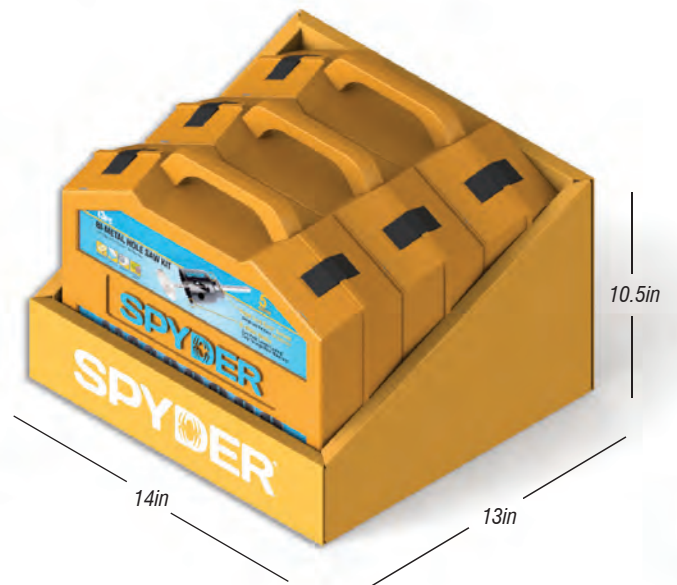

PRO POWERED TOOLS

WOOD BORING FLOORSTAND

900767

Item#	Description	QTY
11001	Spyder 14pc Spade Bit Kit w/ Pouch	12
12001	Spyder 3pc Auger Bit Kit	12
11036-2BONUS	Spyder 6+2pc Spade Bit Kit	24



MACH-BLUE GOO™ COUNTER DISPLAY

900709-COUNTER

Item#	Description	QTY
900709-COUNTER	Mach-Blue Goo Cutting Lubricant, Six 6oz Bottles	1



MERCHANDISING

MACH-BLUE GOO™ GRAVITY RACK (EMPTY)

900831

Item#	Description	QTY
900831	Mach-Blue Goo™ Gravity Rack	1

Holds 6oz bottles of Spyder® Mach-Blue Goo™. Fits a warehouse standard with 1.25" on center holes



3X3™ COUNTER DISPLAY (EMPTY)

200227

Item#	Description	QTY
200227	Reciprocating Saw Blade Counter Display	1

Holds all sizes of Spyder® 3X3™ Reciprocating Saw Blades.



PRO POWERED TOOLS

32-IN ROLLING FLOORSTAND (EMPTY)

Item#	Description	QTY
900585	SPYDER ROLLING DISPLAY PEGBOARD 32IN X 60IN BLACK	1
900586	SPYDER ROLLING DISPLAY BASE	1

Both of these items need to be ordered together. Does not include header.

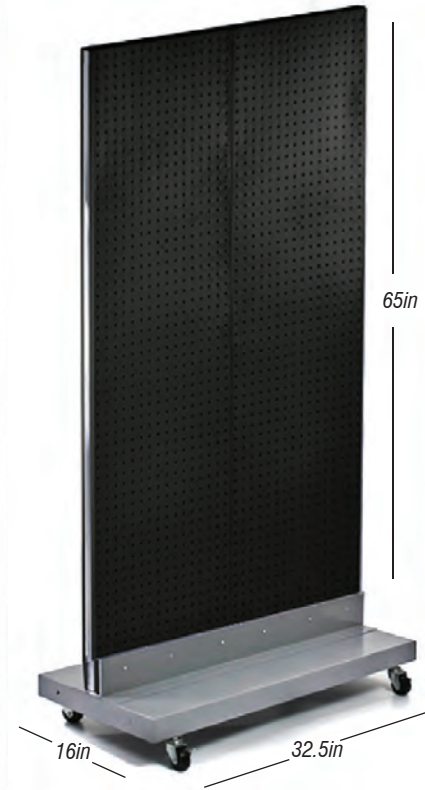

32-IN ROLLING FLOORSTAND HEADER

900576

Item#	Description	QTY
900576	SPYDER ROLLING DISPLAY BRAND HEADER	1

For use on the rolling display (not included).

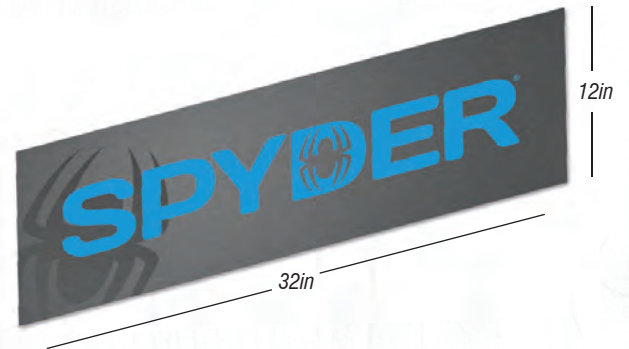

BI-METAL HOLE SAW SHELF - SMALL

600967

Item#	Description	QTY
600967	Bi-Metal HS Shelf - SM	

Holds sizes 3/4" to 2" of Spyder® Bi-Metal Hole Saws.

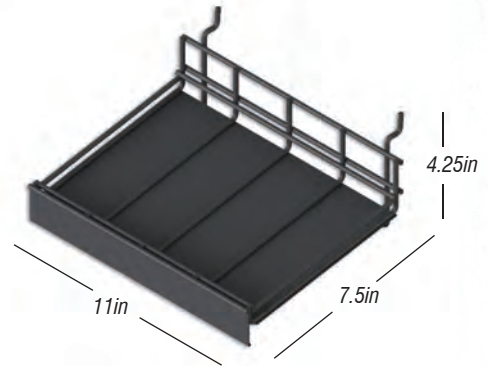

BI-METAL HOLE SAW SHELF - MEDIUM

600968

Item#	Description	QTY
600968	Bi-Metal HS Shelf - MED	

Holds sizes 1-1/2" to 4" of Spyder® Bi-Metal Hole Saws.

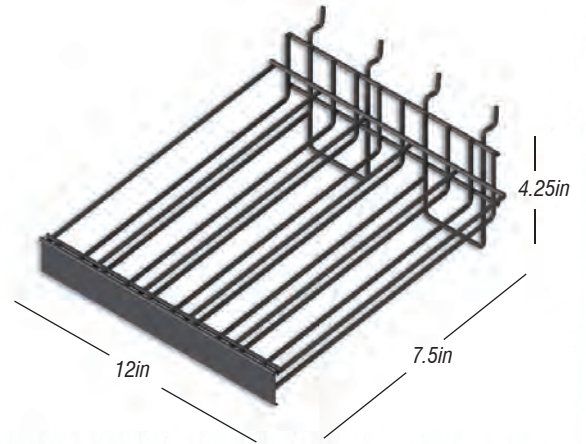

BI-METAL HOLE SAW SHELF - LARGE

600969

Item#	Description	QTY
600969	Bi-Metal HS Shelf - LG	

Holds sizes 3" and over of Spyder® Bi-Metal Hole Saws.

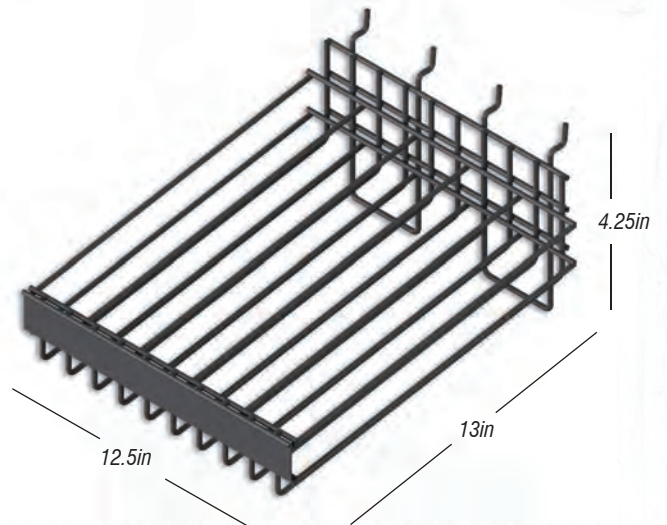

MERCHANDISING

PRO POWERED TOOLS

TUNGSTEN CARBIDE TIPPED HOLE SAW SHELF - SMALL

600970

Item#	Description	QTY
600970	TCT SM HS Shelf	

Holds sizes $\frac{3}{4}$ " to 2" of Spyder® Tungsten Carbide Tipped (TCT) and TARANTULA Hole Saws.

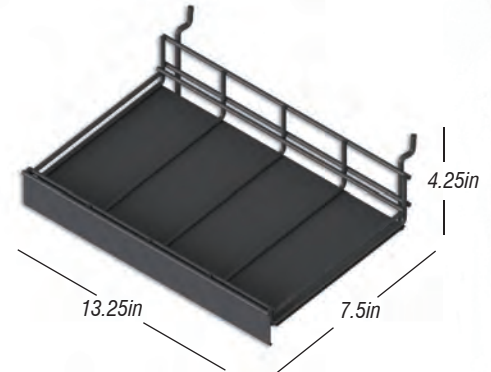

TUNGSTEN CARBIDE TIPPED HOLE SAW SHELF - MEDIUM

600971

Item#	Description	QTY
600971	TCT MED HS Shelf	

Holds sizes 1- $\frac{1}{2}$ " to 4" of Spyder® Tungsten Carbide Tipped (TCT) and TARANTULA Hole Saws.

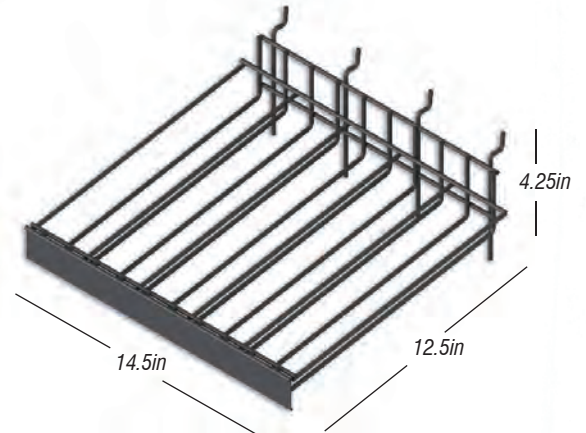

TUNGSTEN CARBIDE TIPPED HOLE SAW SHELF - LARGE

600972

Item#	Description	QTY
600972	TCT LG HS Shelf	

Holds sizes 3" and over of Spyder® Tungsten Carbide Tipped (TCT) and TARANTULA Hole Saws.

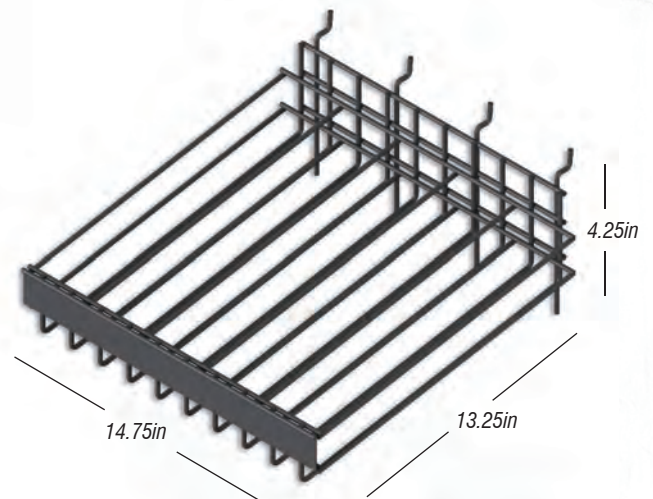

HOLE SAW SHELF SLOTWALL MOUNT

600973

Item#	Description	QTY
600973	Hole Saw Shelf Slotwall Mount	See Below

A flexible rack for use with hole saw shelves when used with slotwall fixtures.

For Item#	Description	QTY REQUIRED
600985	Plumbing TCT Hole Saw POG	1
600984	Electrical TCT Hole Saw POG	1
600983	Everyday TCT Hole Saw POG	2
600988	Plumbing Tarantula Hole Saw POG	1
600987	Electrical Tarantula Hole Saw POG	1
600986	Everyday Tarantula Hole Saw POG	1
600982	Plumbing Bi-Metal Hole Saw POG	1
600981	Electrical Bi-Metal Hole Saw POG	1
600980	Everyday Bi-Metal Hole Saw POG	2

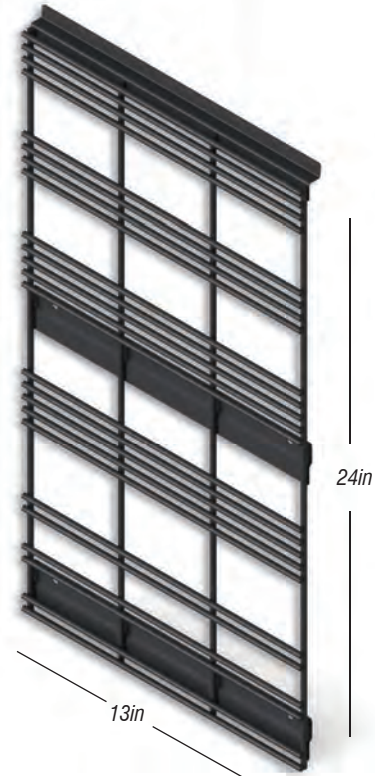

BI-METAL HOLE SAW RACK (EMPTY)

600930

Item#	Description	QTY
600934	Hole Saw Rack - Bi-Metal Blade Rack (empty)	1

Holds all sizes of Spyder Bi-Metal Hole Saws.

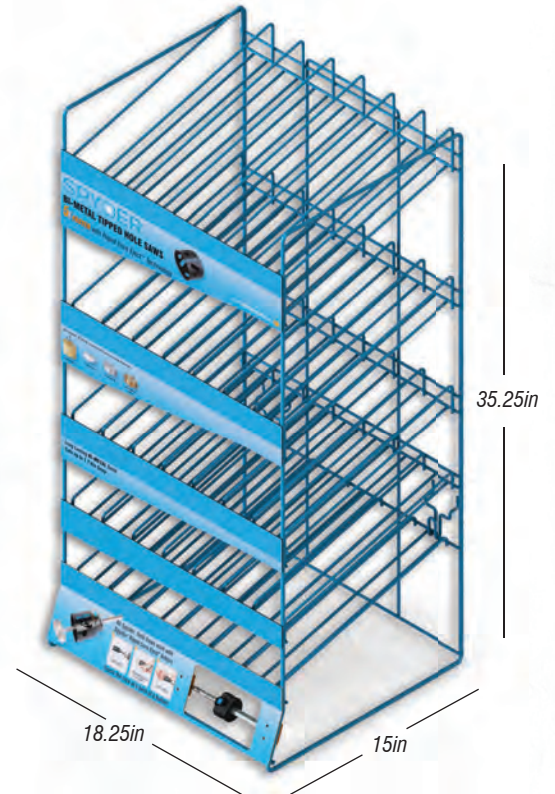

PRO POWERED TOOLS

TUNGSTEN CARBIDE TIPPED (TCT) HOLE SAW RACK (EMPTY)

600930

Item#	Description	QTY
600930	Hole Saw Rack - TCT Wood/Masonry Blade Rack (empty)	1

Holds all sizes of Spyder Tungsten Carbide Tipped (TCT) Hole Saws.

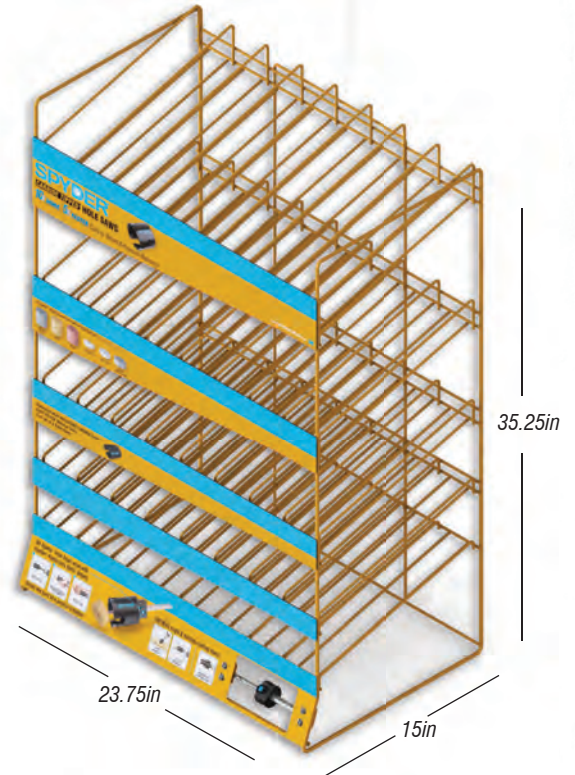

TARANTULA™ TUNGSTEN CARBIDE TIPPED HOLE SAW RACK (EMPTY)

600971

Item#	Description	QTY
600971	TCT MED HS Shelf	

Holds all sizes of Spyder TARANTULA™ Tungsten Carbide Tipped Hole Saws.

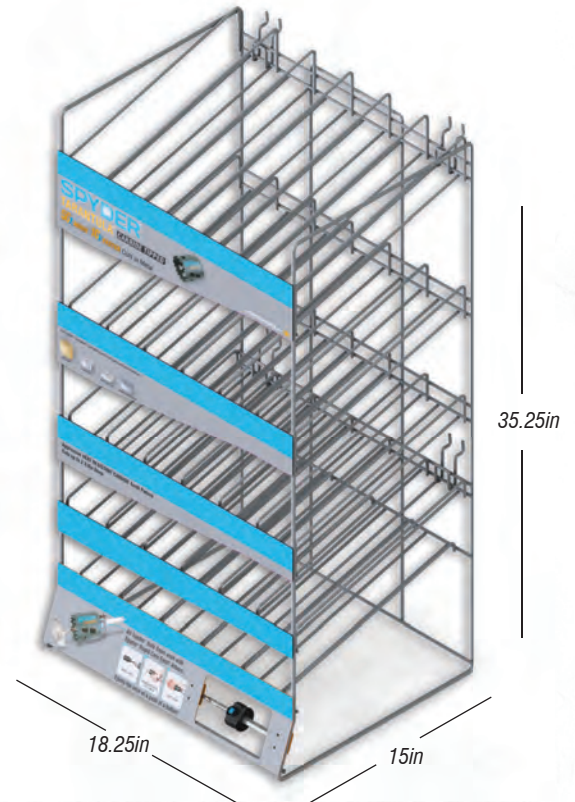

MERCHANDISING

LARGE RECIP ACCESSORIES RACK (EMPTY)

900471

Item#	Description	QTY
900471	14pc Wire Display Rack for 3x3 Blades & Recip Accessories (empty)	1

Recommended product assortment:

For Item#	Description	QTY
900471	14pc Recip Accessories	1
900839	EVERYDAY 14pc Recip Backer Card	1
319	SPY Scraper 2" Bulk - with barcode printed on back	2
320	SPY Scraper 4" Bulk - with barcode printed on back	2
321	SPY Scraper 6" Bulk - with barcode printed on back	2
243	SPY Scraper Stacked Multi-Blade Skin Pack, 2,4,6in	2
100263	SPY Grout-Out™ Narrow Single - Bulk w/ UPC	2
100264	SPY Grout-Out™ Wide Single - Bulk w/ UPC	2
400005	SPY Wire Brush - Bulk with UPC	2
400006	SPY Nylon Brush - Bulk with UPC	2
200176	SPY 3X3™ - 6x10 TPI - 6"	10
200177	SPY 3X3™ - 6x10 TPI - 8"	10
200179	SPY 3X3™ - 10x14 TPI - 8"	10
200180	SPY 3X3™ - 14x18 TPI - 6"	10
200204	SPY 3X3™ - 10/14x14 TPI - 10" Extreme Metal	10
200207	SPY 3X3™ - 8/12x10 TPI - 10" Advanced Demo	10

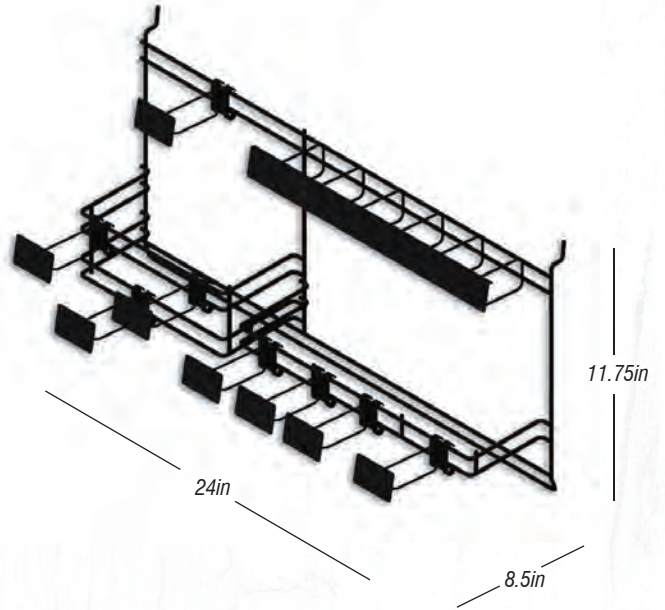

LARGE RECIP ACCESSORIES BACKER CARD

900839

Item#	Description	QTY
900839	EVERYDAY Backer Card for 14pc Recip Wire Display Rack	1

Backer card for 900471.

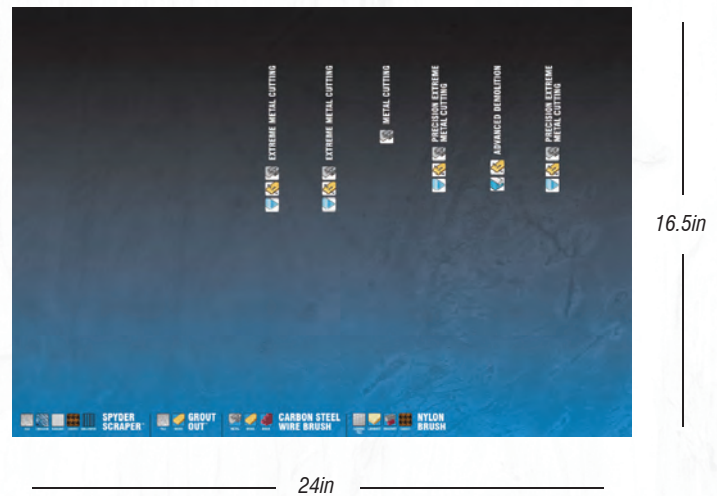

PRO POWERED TOOLS

SMALL RECIP ACCESSORIES RACK (EMPTY)

900717

Item#	Description	QTY
900717	8pc Recip Accessory Rack (empty)	1

Recommended product assortment:

Item#	Description	QTY
900717	8pc Recip Accessory Rack	1
900840	8pc Recip Backer Card	1
319	SPY Scraper 2" BULK - with barcode printed on back	2
320	SPY Scraper 4" BULK - with barcode printed on back	2
321	SPY Scraper 6" BULK - with barcode printed on back	2
243	SPY Scraper Stacked Multi-Blade Skin Pack, 2,4,6in	2
100263	SPY Grout-Out™ Narrow Single - Bulk w/ UPC	2
100264	SPY Grout-Out™ Wide Single - Bulk w/ UPC	2
400005	SPY Wire Brush - Bulk with UPC	2
400006	SPY Nylon Brush - Bulk with UPC	2
500010	SPY Recip Sander w/ Sandpaper	2
100234	SPY Spyder Grout-Out Multi-Pack	2

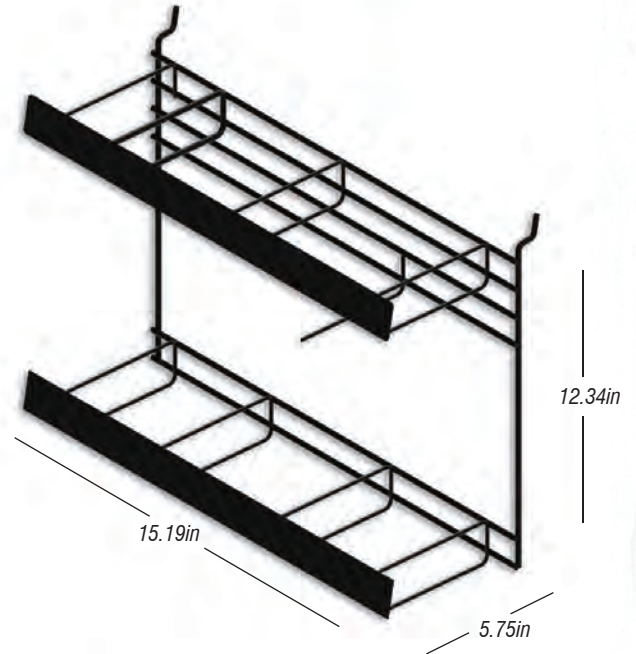

SMALL RECIP ACCESSORIES BACKER CARD

900840

Item#	Description	QTY
900840	8PC Recip Backer Card	1

Backer card for 900717.

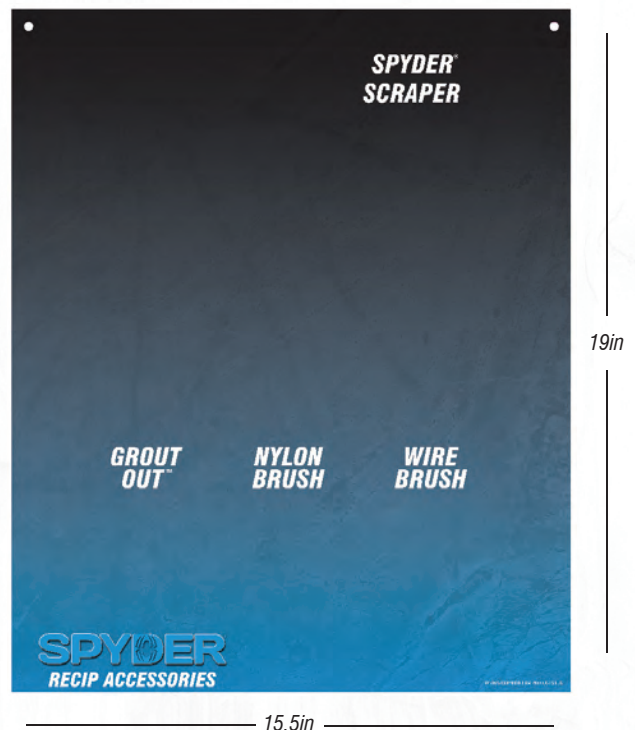

MERCHANDISING

RECIP RACK (EMPTY, FOR LONG RECIP BLADES)

900473

Item#	Description	QTY
900473	Recip Rack	1

Recommended product assortment:

Item#	Description	QTY
319	SPY Scraper 2" Bulk	2
320	SPY Scraper 4" Bulk	2
321	SPY Scraper 6" Bulk	2
100263	SPY Grout-Out™ Narrow Single Bulk	2
400005	SPY Wire Brush - Bulk	2
400006	SPY Nylon Brush - Bulk	2
200211	SPY TCT 18" Recip Blade	2
200209	SPY TCT Recip Blade - 9"	2

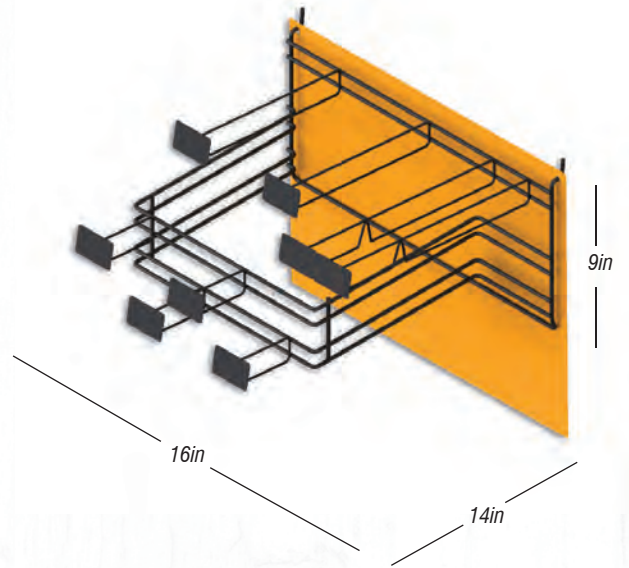

RECIP BACKER CARD

900841

Item#	Description	QTY
900841	Recip Backer Card	1

Replacement backer card for 900473.

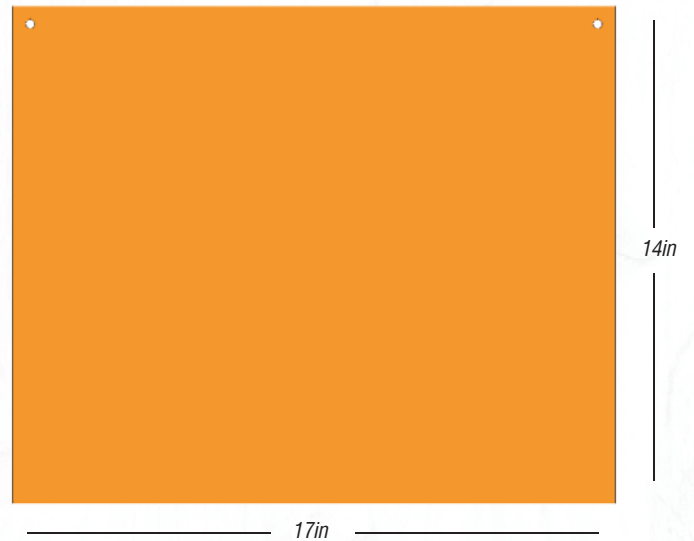

PRO POWERED TOOLS

SMALL DIAMETER CIRCULAR SAW BLADE PEGBOARD RACK (EMPTY)

900720

Item#	Description	QTY
900720	Inline Circ Saw Shelf for CSB	1

For use with 7-1/4" diameter saw blades and smaller.

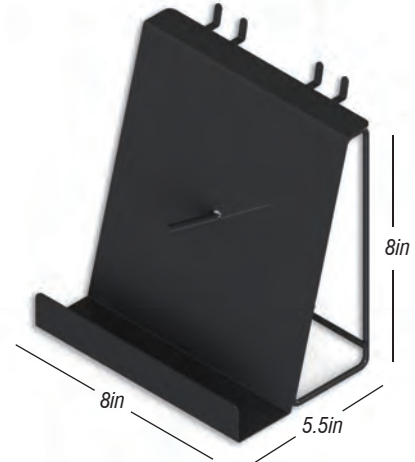

CIRCULAR SAW BLADE BACKER BUNDLE

13510

Item#	Description	QTY
13510	SM Circular Saw Blade Backer Cards	1

13 versions of our most popular blades prepunched to go behind blades. For use with individual 900720 racks.



LARGE DIAMETER CIRCULAR SAW BLADE HANGING RACKS (EMPTY)

Item#	Description	QTY
13507	199 CS Small Hanging Bracket	1
13508	199 CS Medium Hanging Bracket	1
13509	199 CS Large Hanging Bracket	1

Requires a 4ft gondola with side standards for shelves. Will require separate hooks.

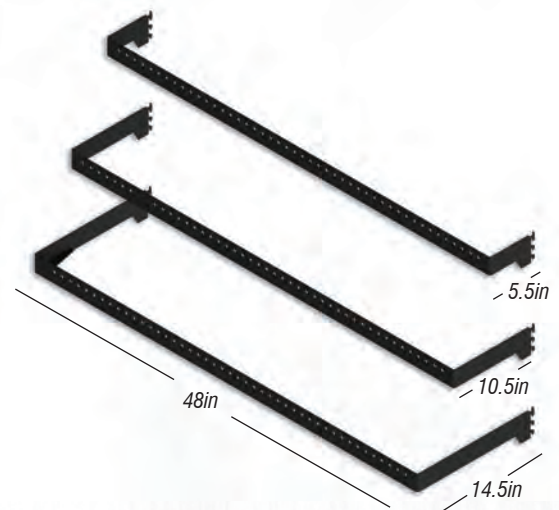

www.spyderproducts.com

6 HOOK RECIP BLADE RACK (EMPTY)

900718

Item#	Description	QTY
900718	6 Hook Recip Blade Rack	1

Wire hook diameter is .120". Use this rack for 3X3™ Reciprocating blades and other recip accessories.

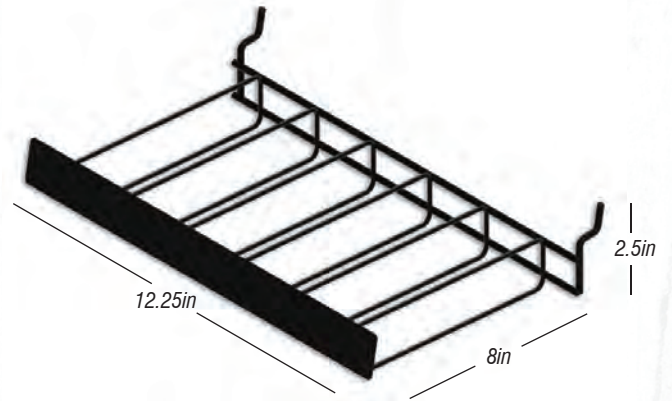

3 HOOK RECIP BLADE RACK (EMPTY)

900719

Item#	Description	QTY
900719	3 Hook Recip Blade Rack	1

Wire hook diameter is .120". Use this rack for 3X3™ Reciprocating blades and other recip accessories.

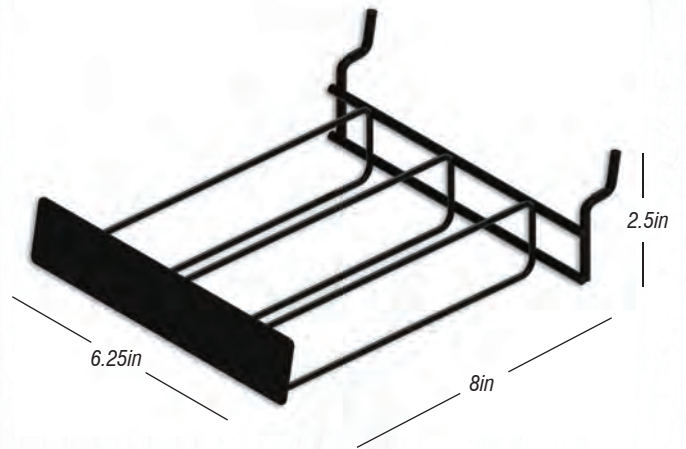

10pc PILOT & ARBOR RACK (EMPTY)

900722

Item#	Description	QTY
900722	Pilot Arbor Display	1

Recommended product assortment:

Item#	Description	QTY
600634P	SPY RCE Arbor & Pilot Bit HSS HEX 10	6
600635P	SPY RCE Arbor & Pilot Bit TCT DRILL HEX 10	6
600645P	SPY Pilot Bit HSS HEX 10	6
600646P	SPY Pilot Bit TCT HEX 10	6
600637P	SPY RCE Arbor & Pilot Bit HSS DRILL HEX 8	2
600638P	SPY RCE Arbor & Pilot Bit TCT DRILL HEX 8	2
600648P	SPY Pilot Bit HSS HEX 8	2
600649P	SPY Pilot Bit TCT HEX 8	2
600868P	SPY Arbor Adapter, Hex 8	2
600869P	SPY Arbor Adapter, Hex 10	2

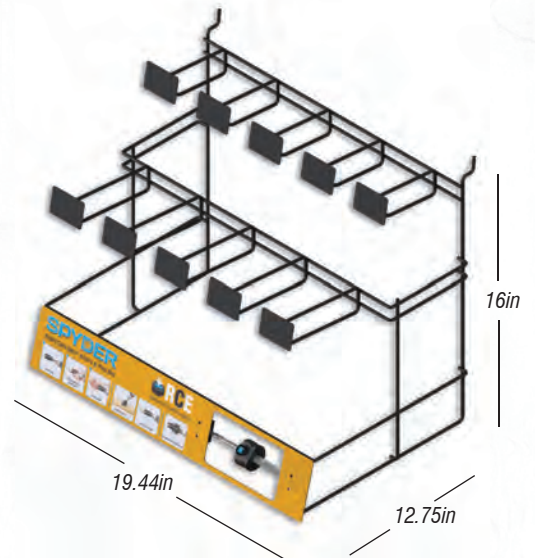

MERCHANDISING

PRO POWERED TOOLS

SPYDER® BRAND BANNER - 2' x 4'

900479

Item#	Description	QTY
900479	Spyder Brand Banner - Size 2'x4'	1

Printed on black banner material.



REORDER BACKER CARDS

900520

Item#	Description	MOQ
900520	Reorder Backer Cards	25

Prepunched to hang on or go behind product hooks



SPYDER® MACH-BLUE GOO™ - 1OZ BOTTLE

900710

Item#	Description	QTY
900710	1 oz. Sample Bottles of Mach-Blue Goo	1

Not for Distributors - Sales Reps (only).



4FT GONDOLA GRAPHIC PANEL

900760

Item#	Description	QTY
900760	4ft Gondola Graphic Panel	1

For use on existing 3ft or 4ft pegboard gondola units similar to Lozier or Madix. Trim to fit using guidelines printed on back.

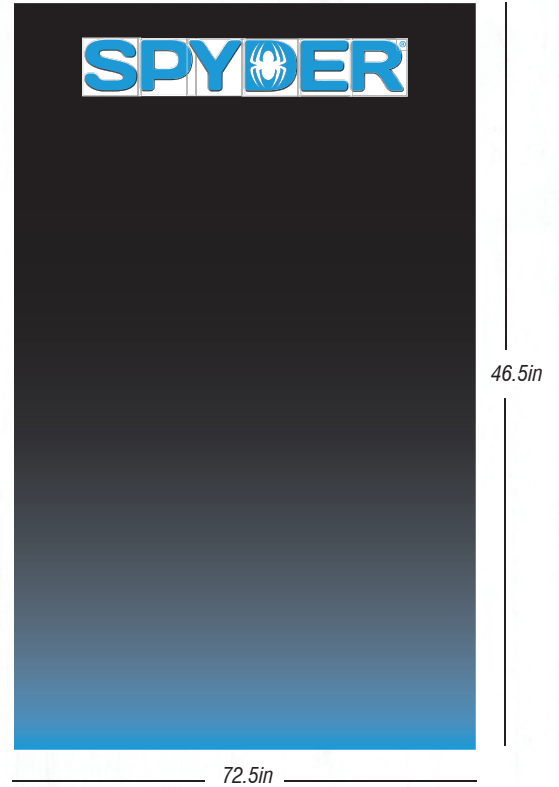

EVERYDAY PEGBOARD HOOKS

Item#	Description	MOQ
900712	4in Pegboard Hook, .187	10
900298	6in Pegboard Hook, .187	10
900713	8in Pegboard Hook, .225	10
900502	8in Pegboard Hook, .212 Black	10

Hooks are galvanized silver or painted black (900502).

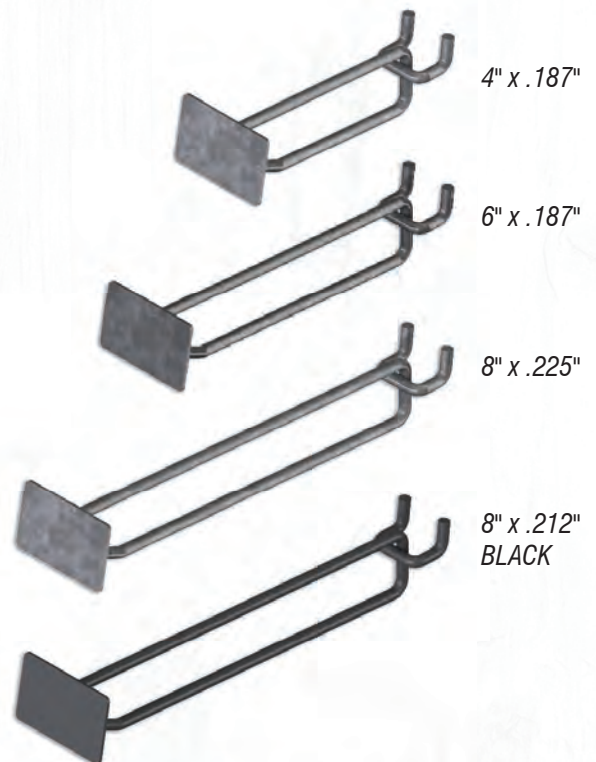



14pc CARBIDE TIPPED HOLE SAW KIT
with Rapid Core Eject™ Technology

UP TO 10X MORE CUTS **UP TO 5X FASTER**

SPYDER

Rapid Core Eject™ System
Drops out the core 5X FASTER!

Tungsten Carbide-Tipped
Up to 10X MORE CUTS | 5X FASTER than standard hole saws!

SPYDER

1/2" (Hex 10) High-Speed Steel

1/2" (Hex 10) Arbor Adapter

1/2" (Hex 10) Tungsten Carbide

600880

See back for additional instructions and warnings.



© 2023 SM Products, LLC. The Spyder Rapid Core Eject™ Hole Saw System is patented in the US and Canada, US Patent no. 7,934,893 and Canada Patent no. 2,589,999. The Spyder logo, Rapid Core Eject, Skeleton, Mach-Blue, Stinger, Tarantula, Power Bits, 3x3, Diamond Bite, Spyder Scraper, Black Series, and Grout-Out are trademarks of SM Products, LLC. All rights reserved.

SM Products, LLC • 1-888-471-2239 • info@spyderproducts.com

www.spyderproducts.com 